

MANUAL 1

12348 1/48 USAF A-10C '75th FS Flying Tigers'

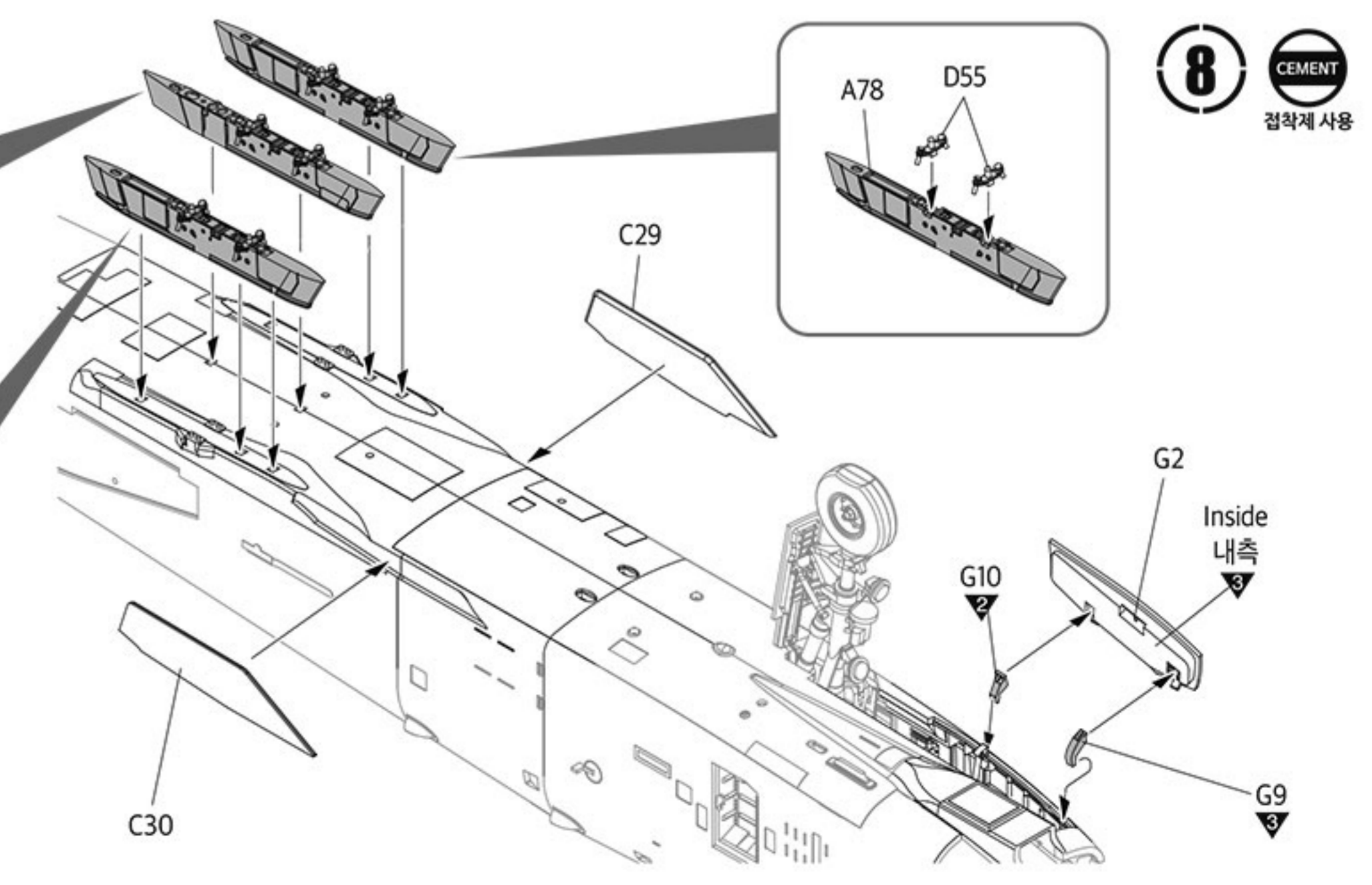

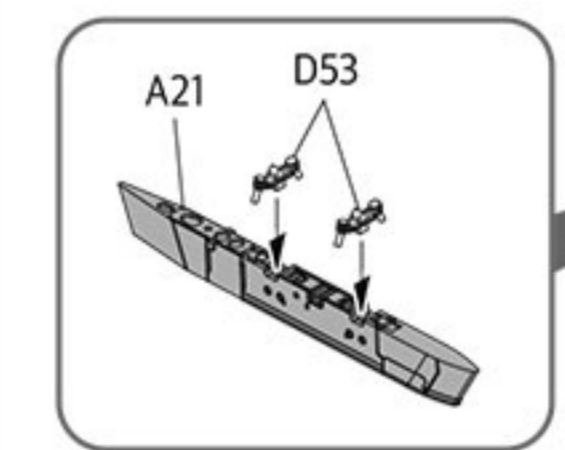

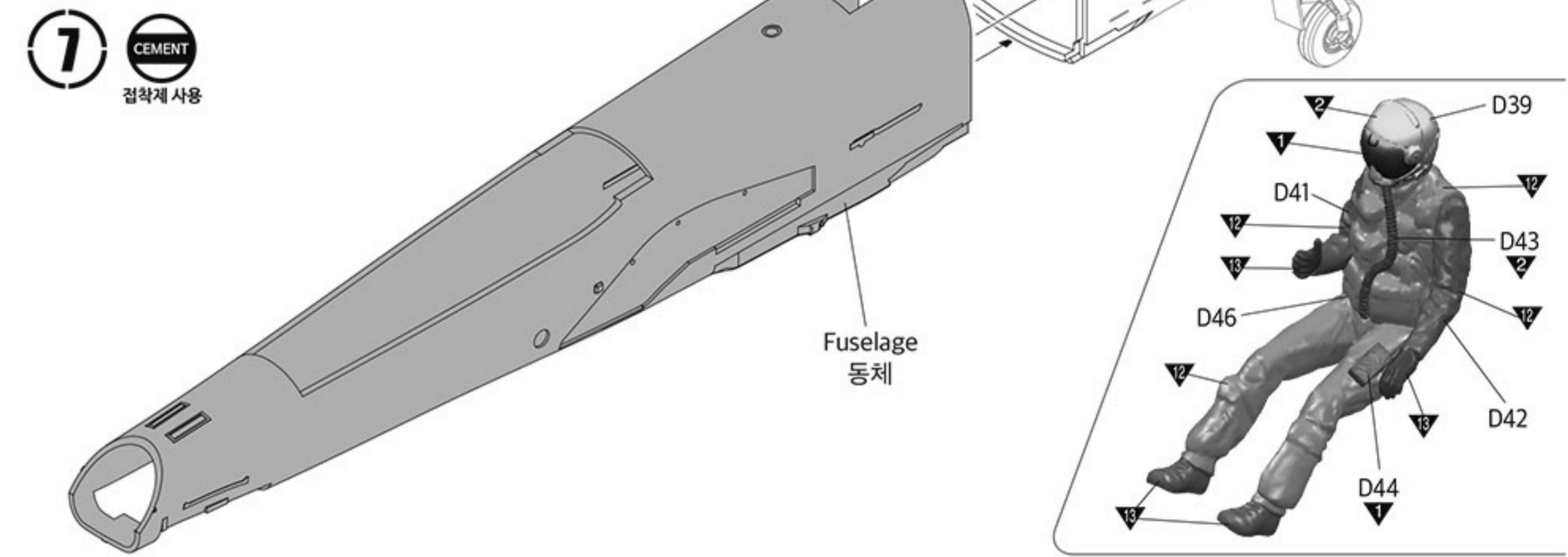
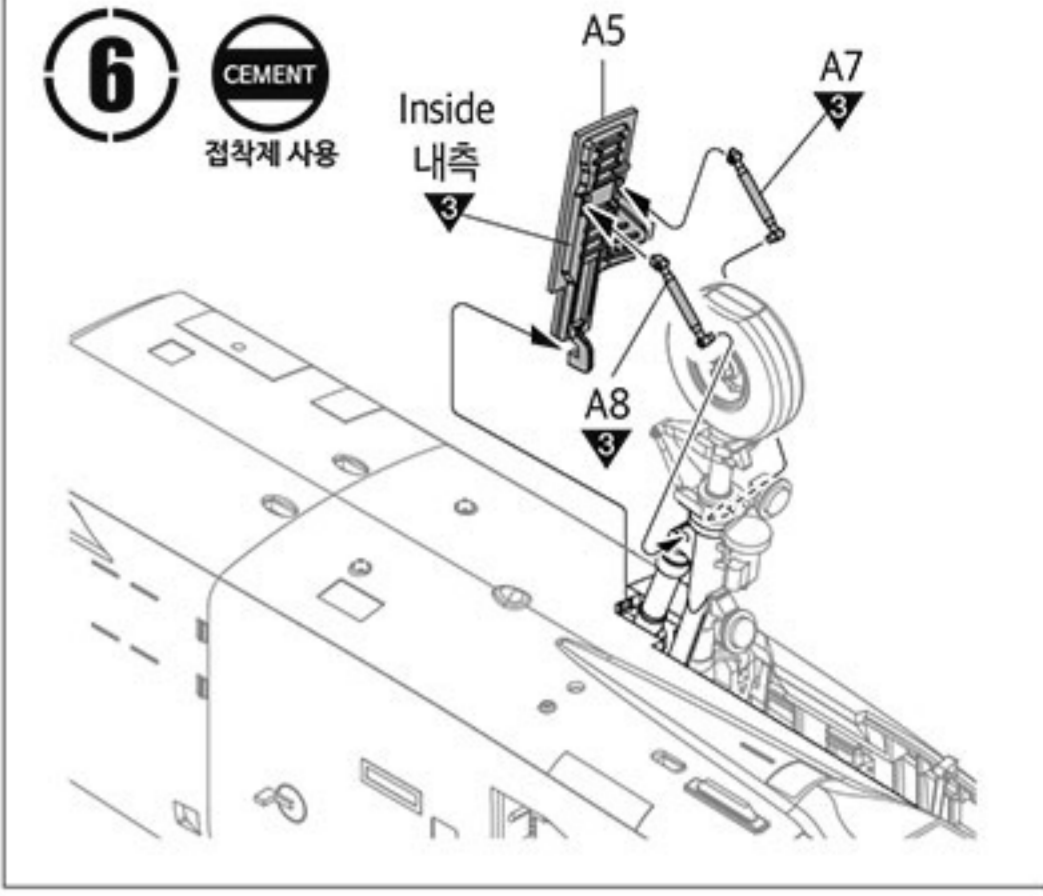
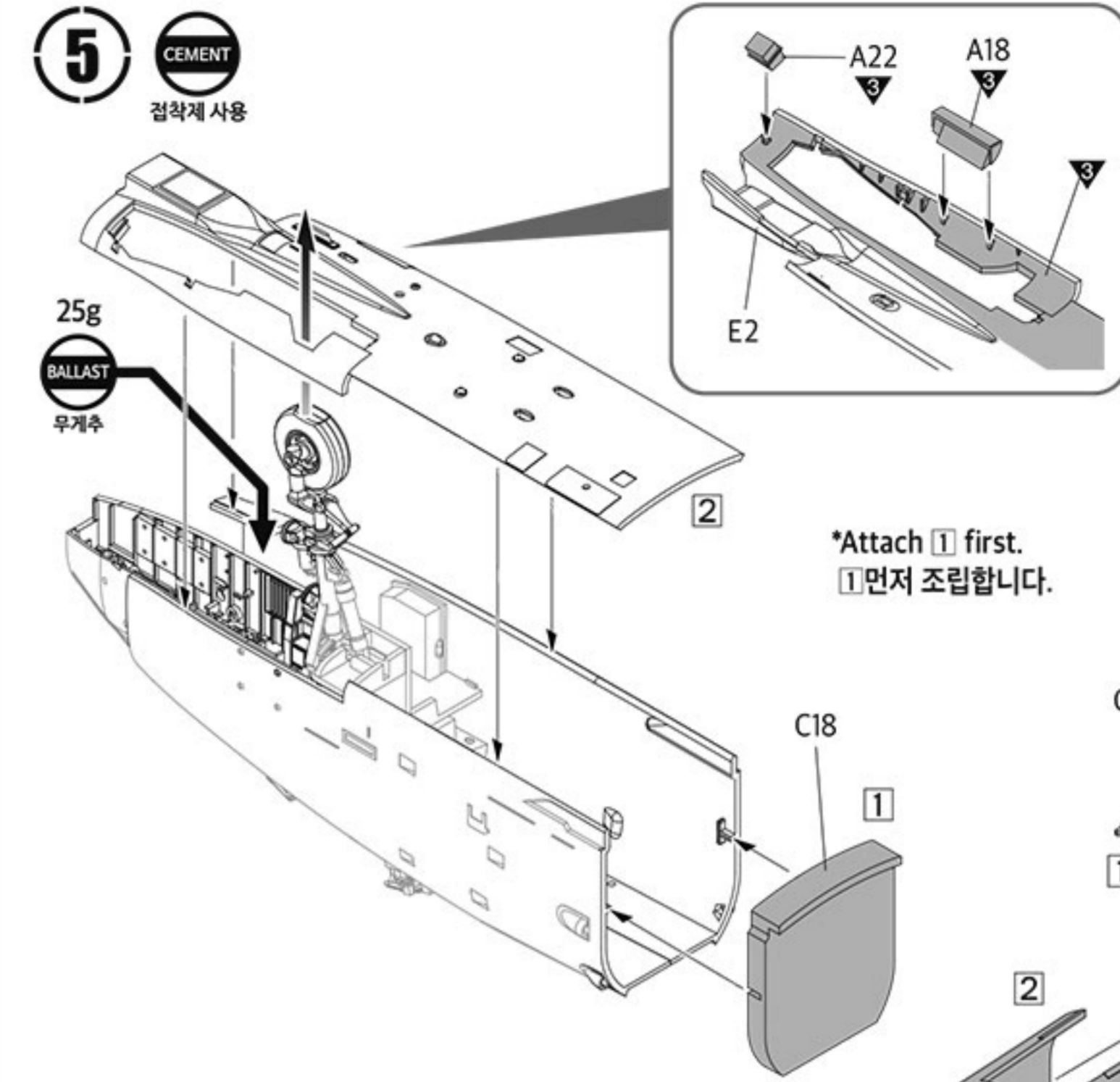
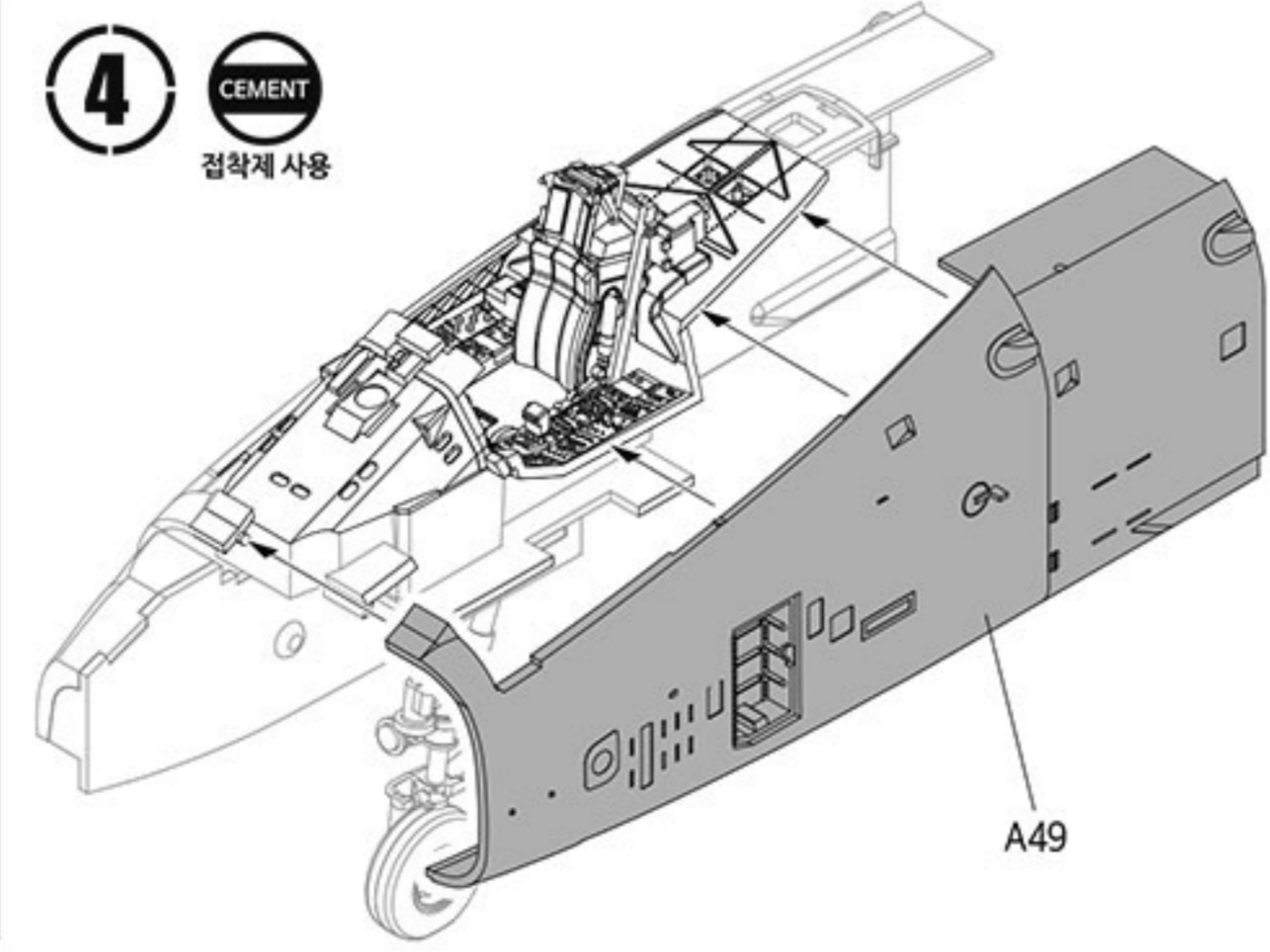
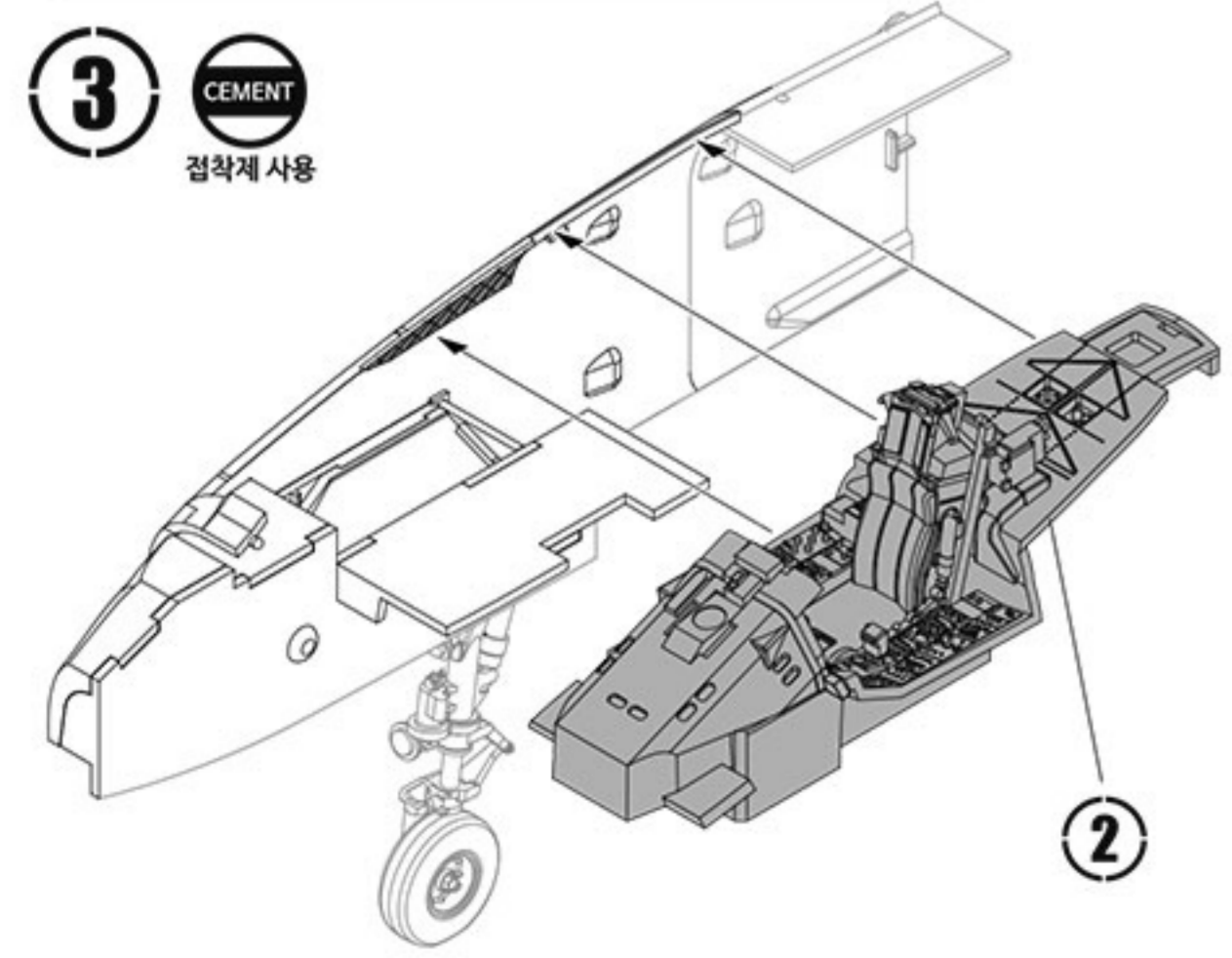
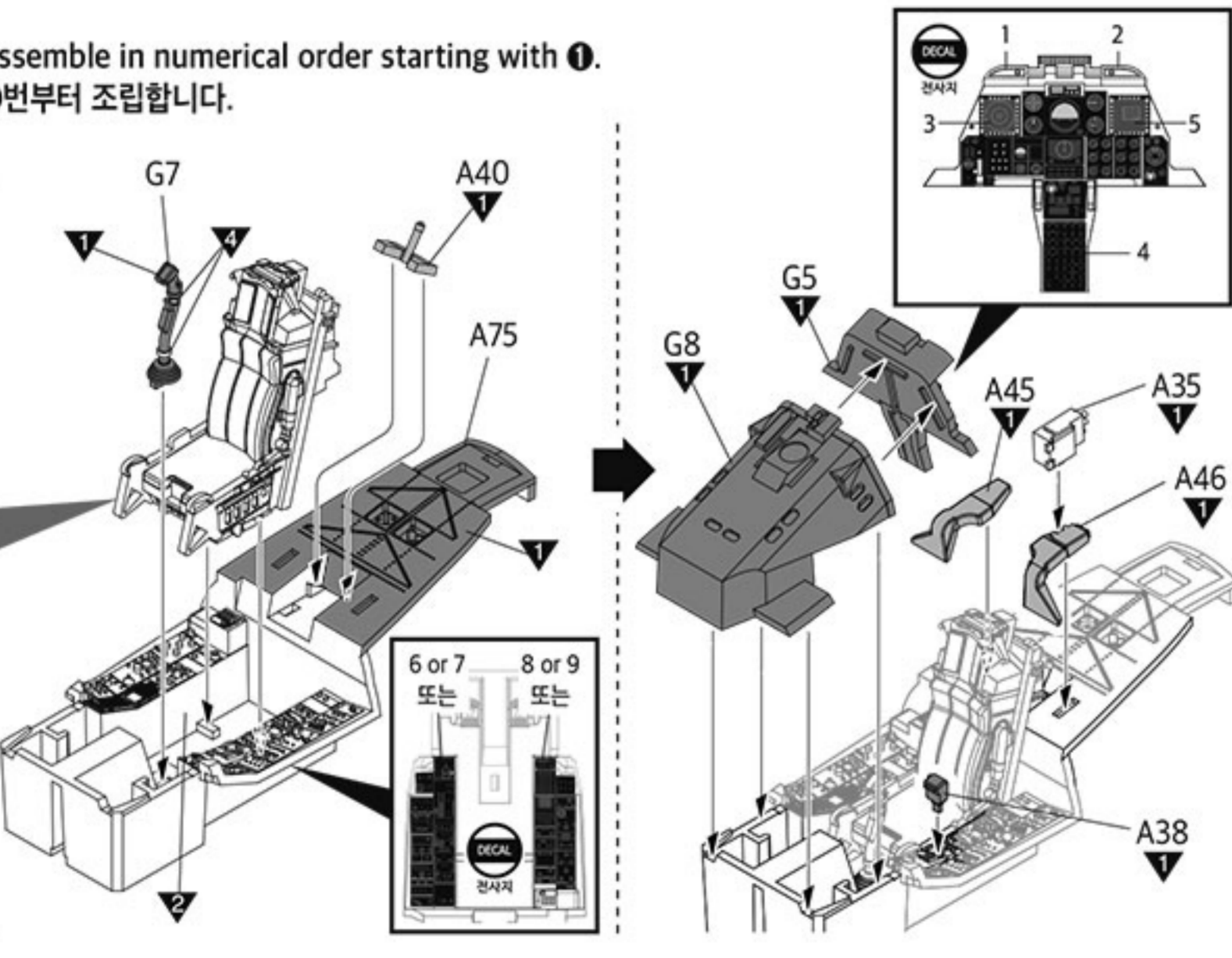
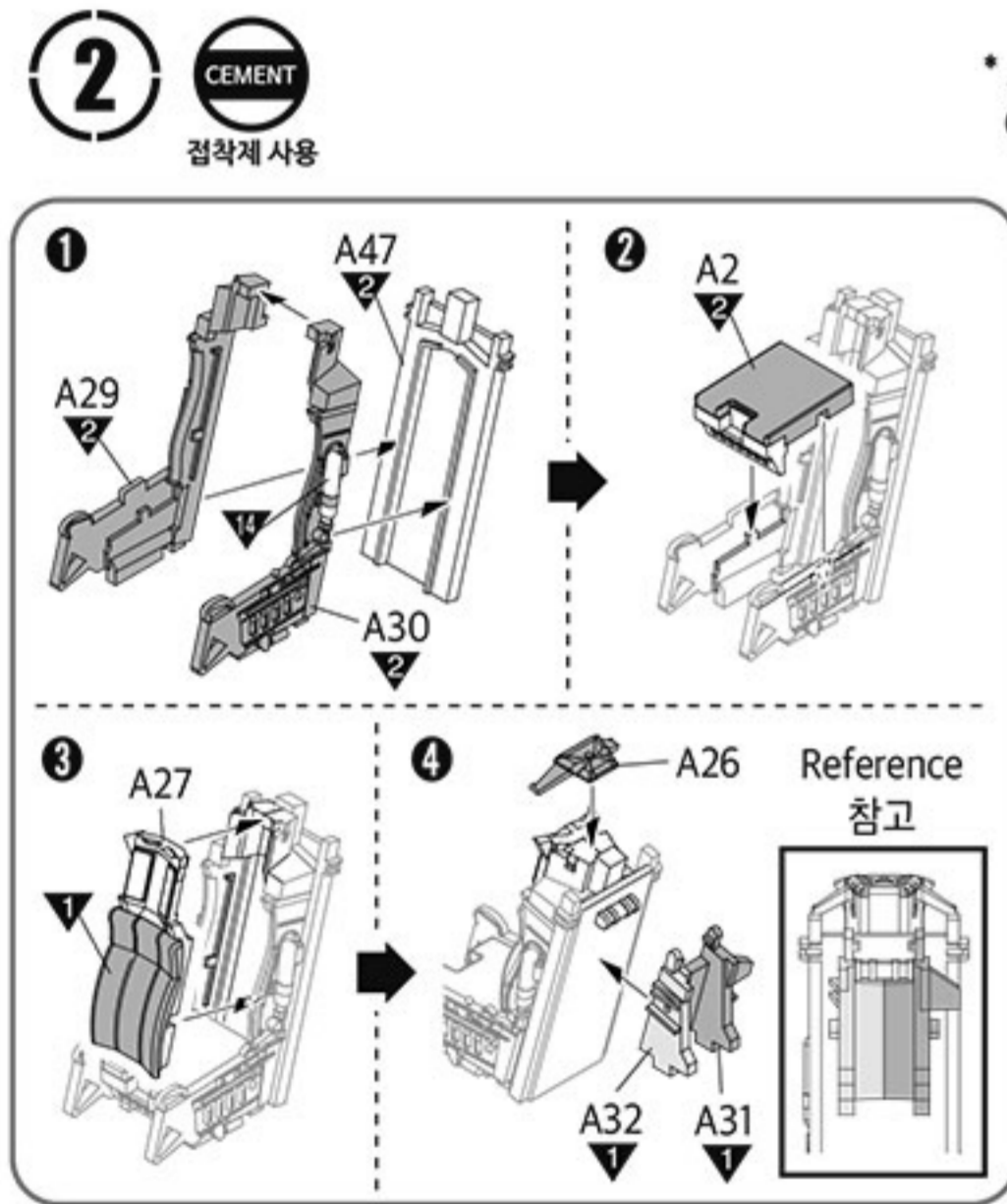
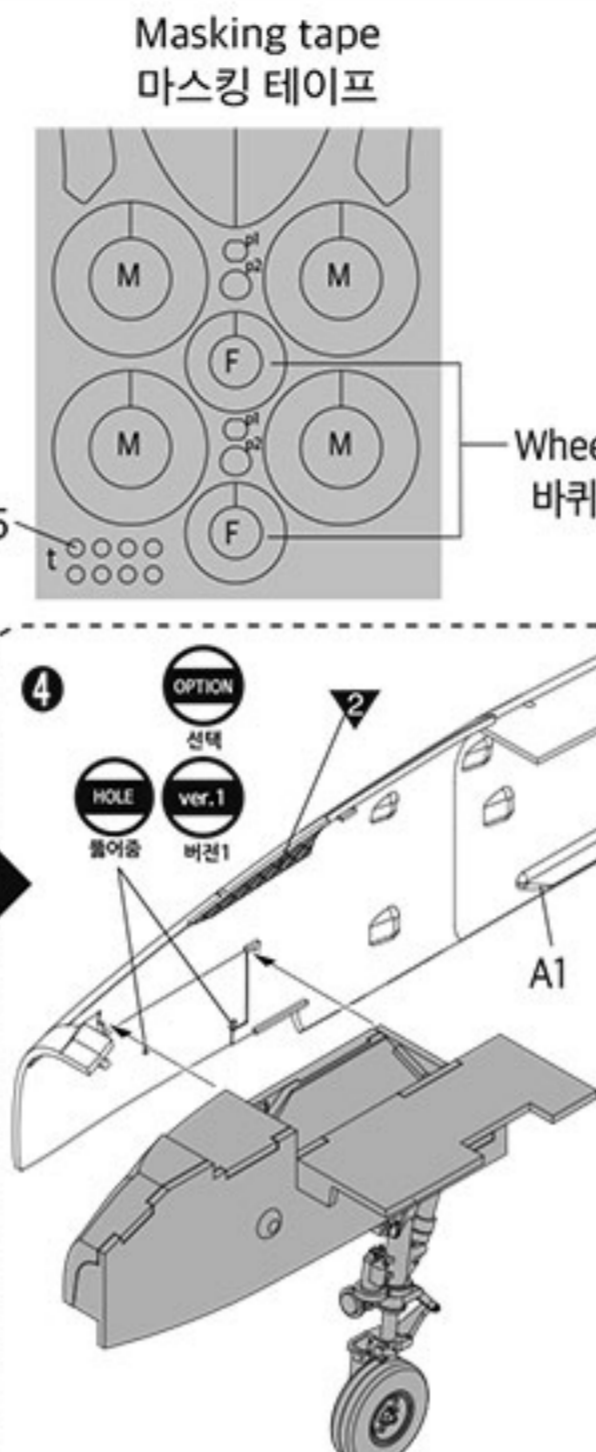
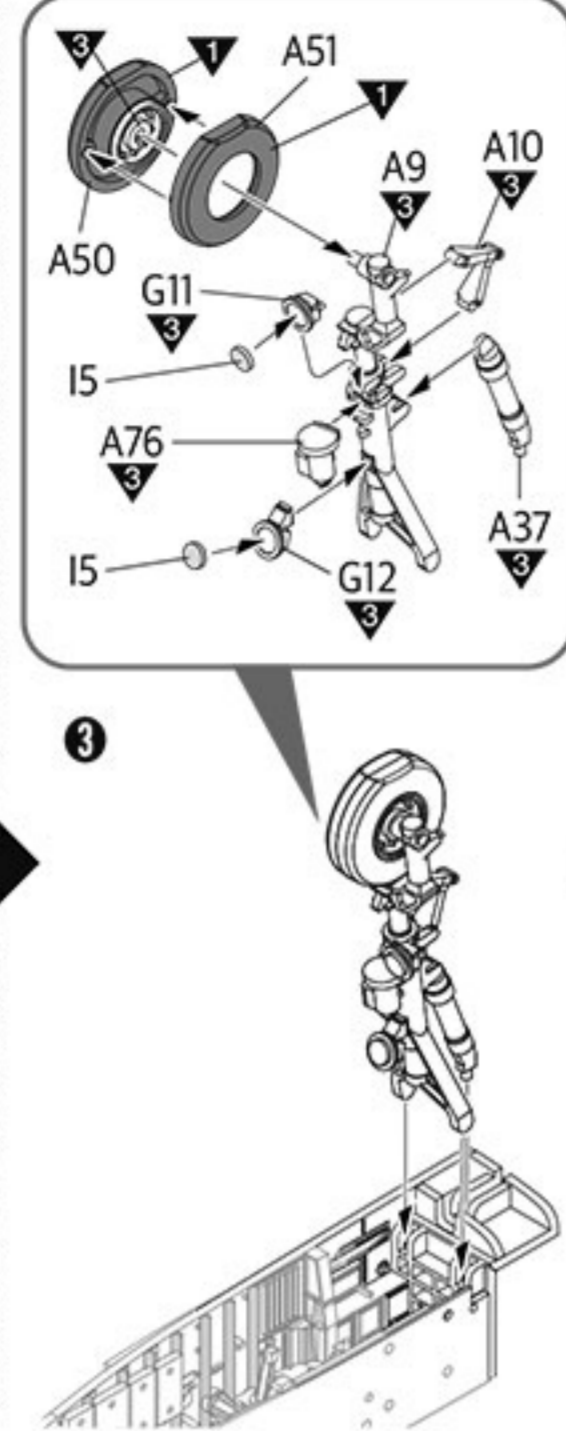
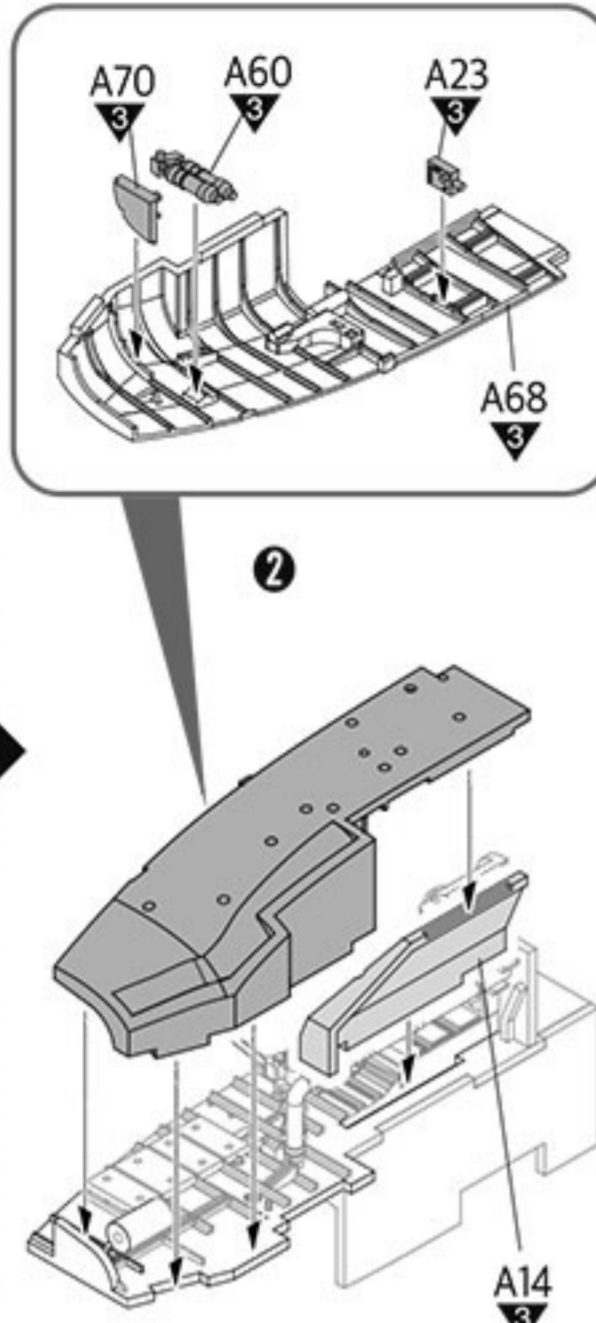
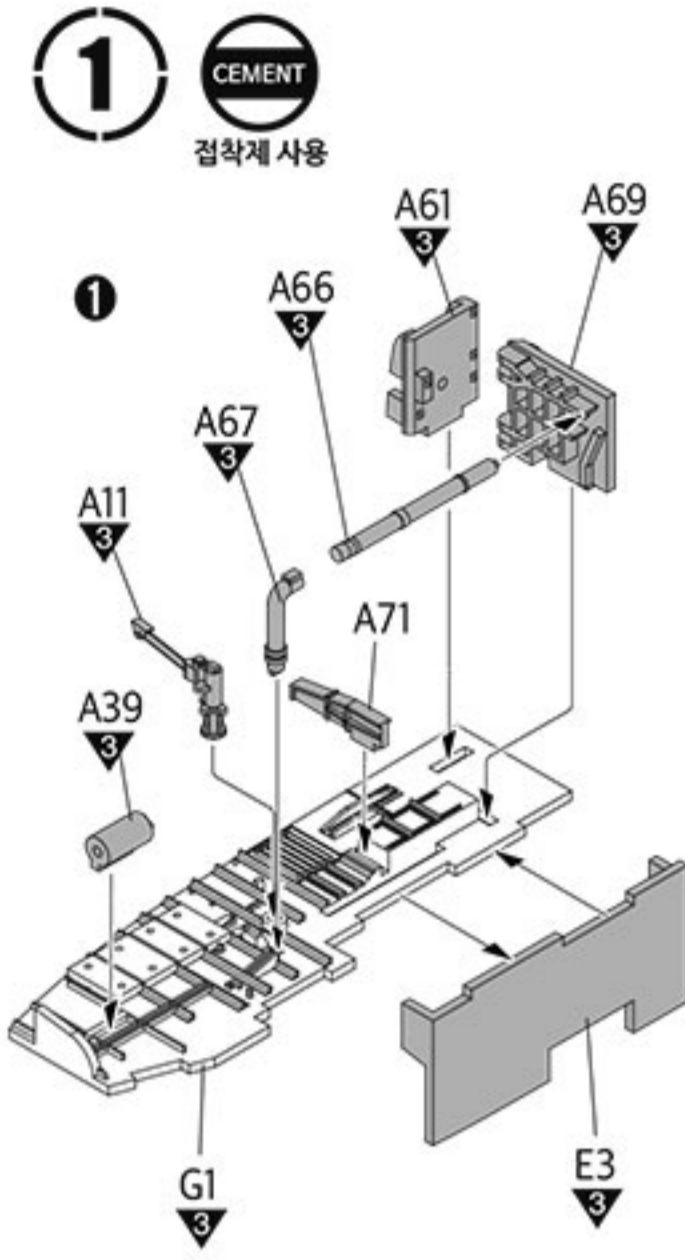
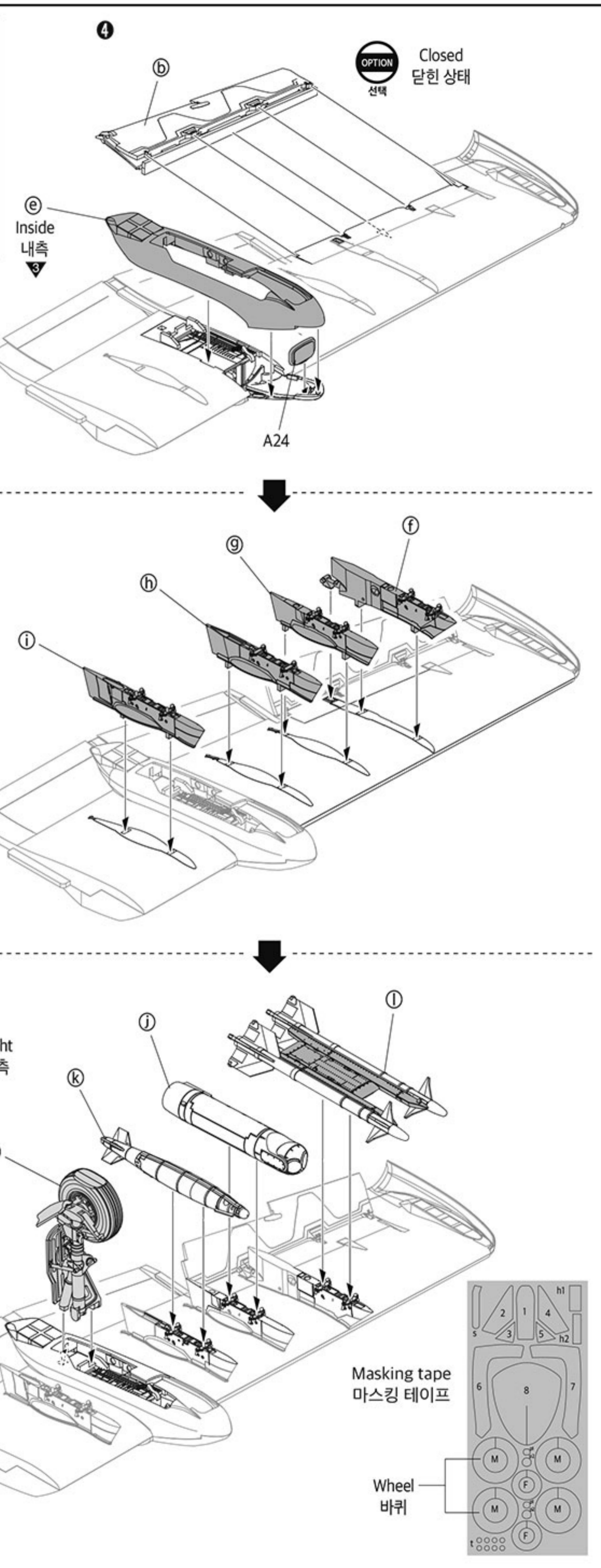
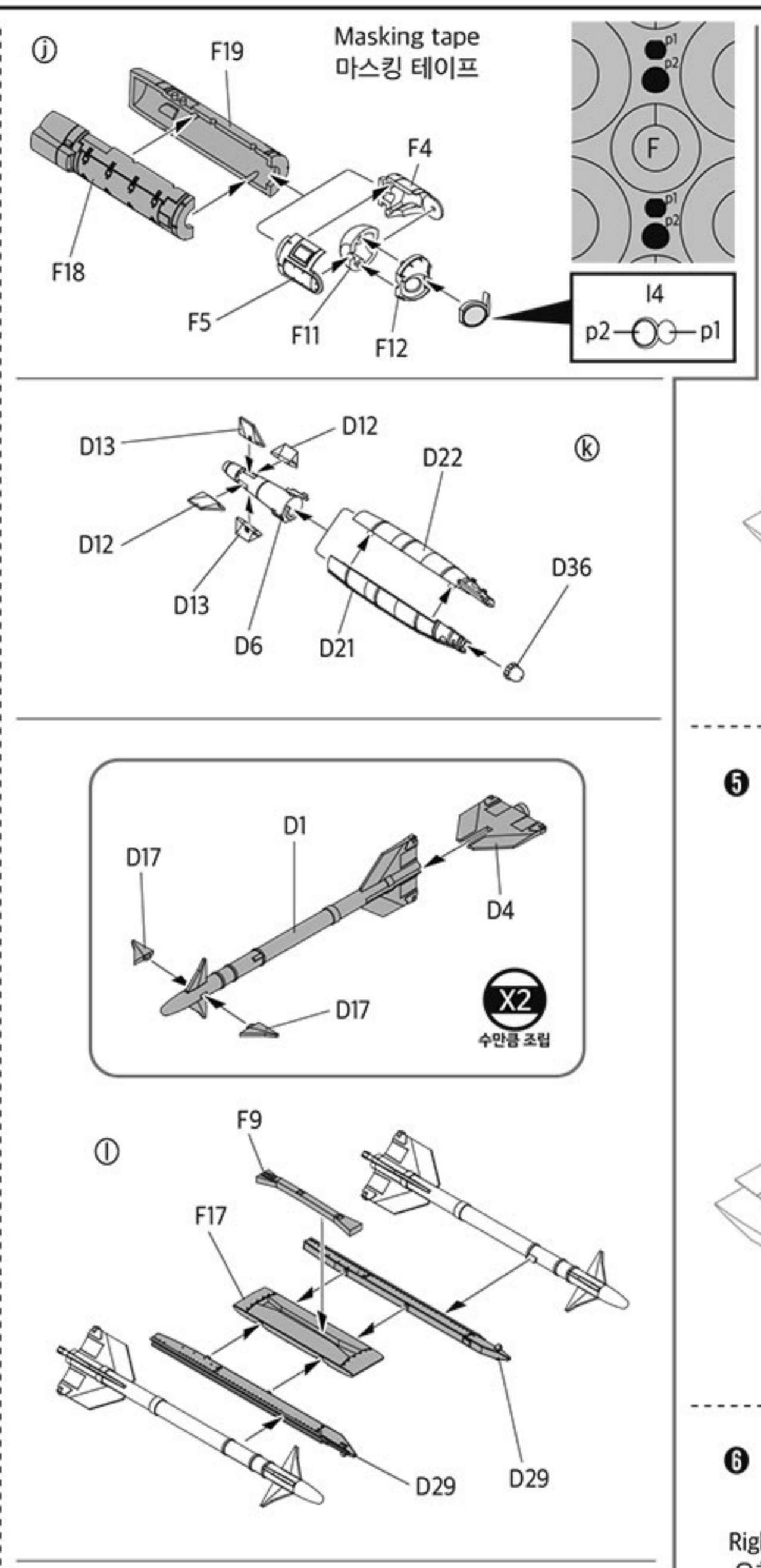
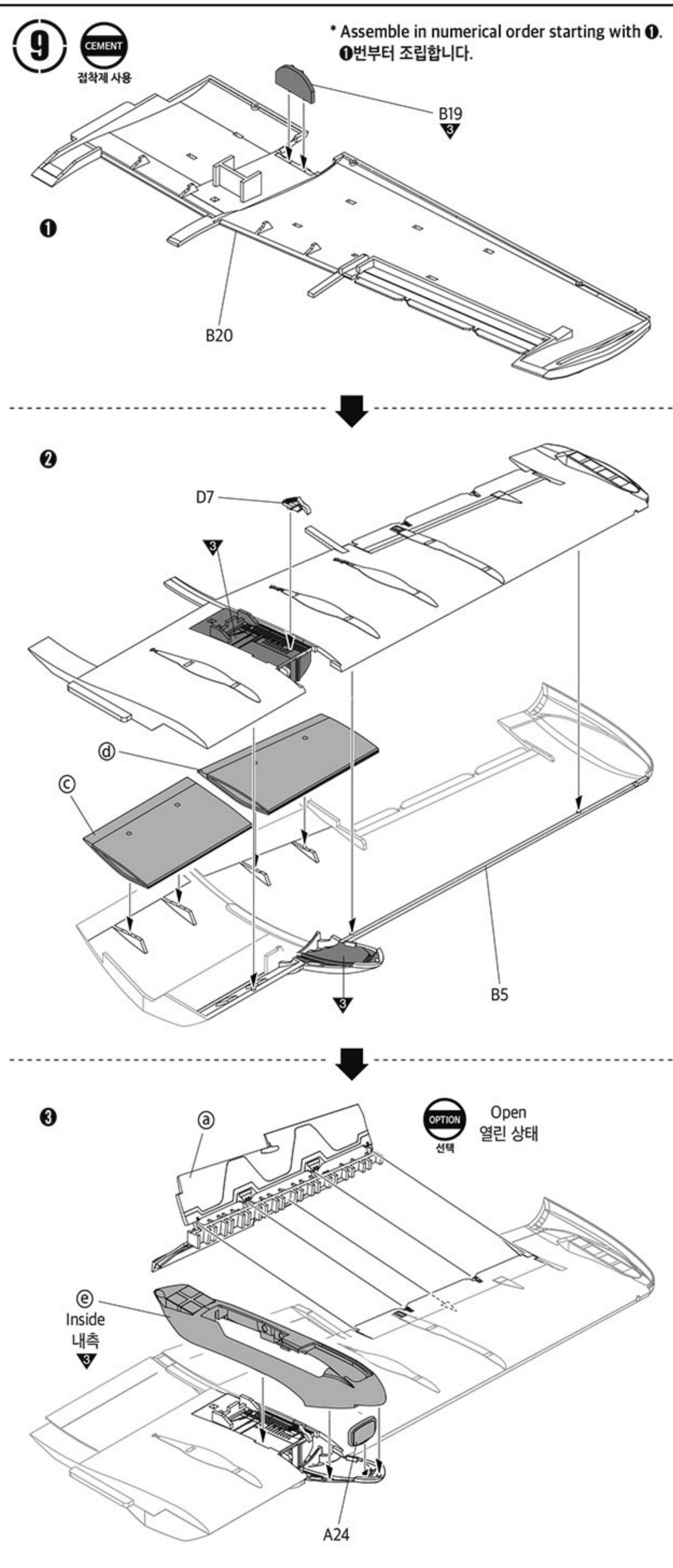
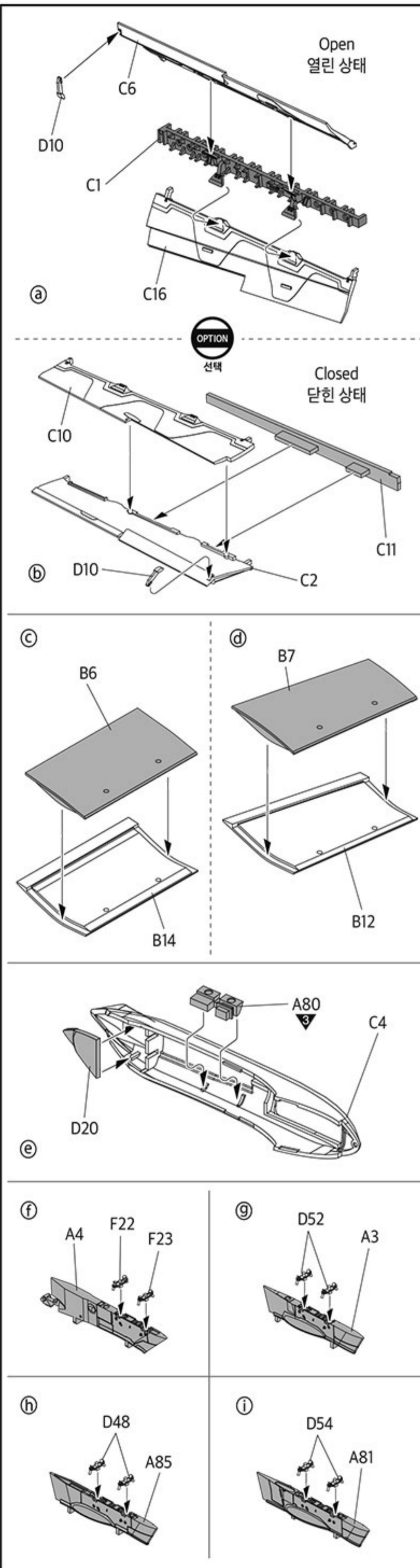
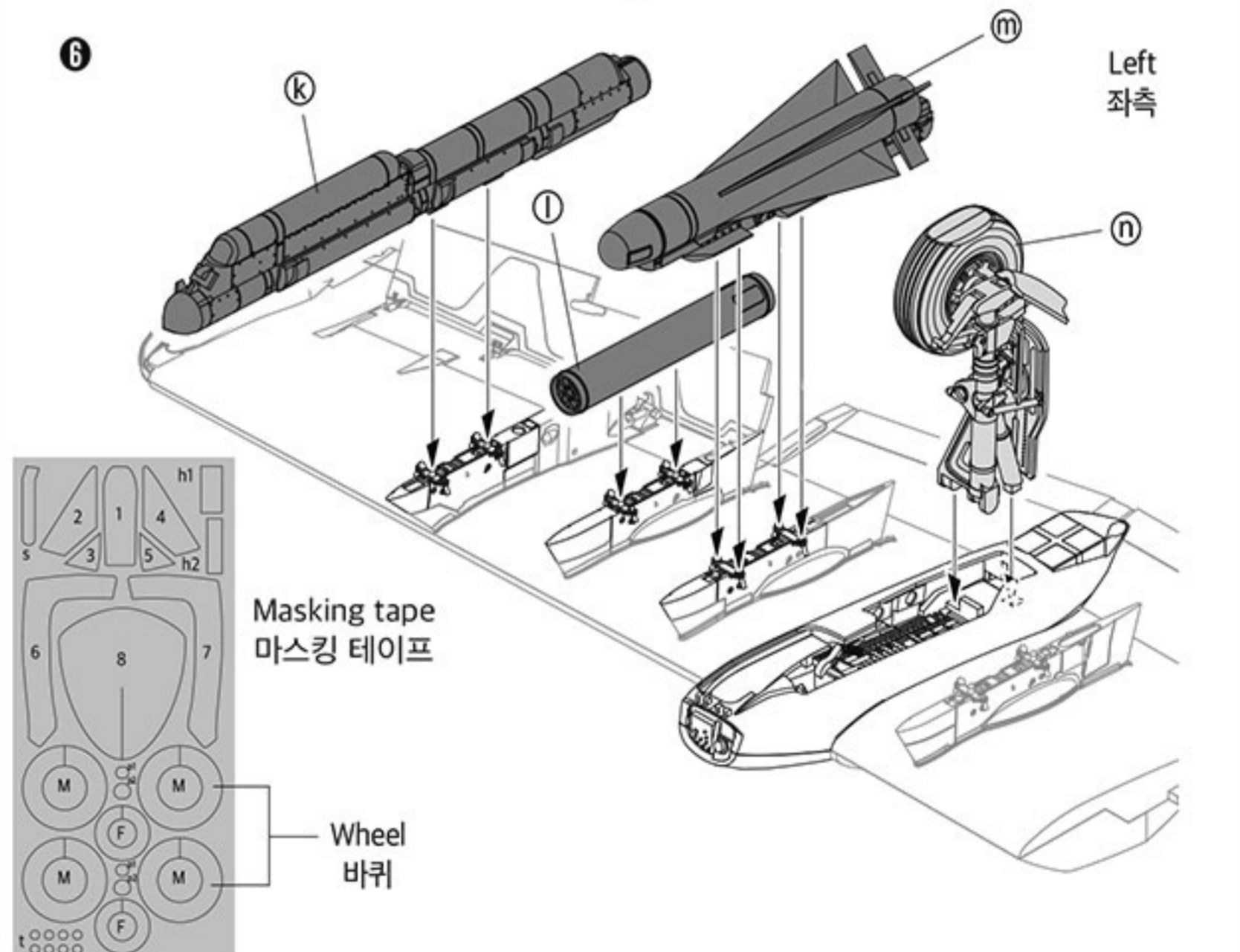
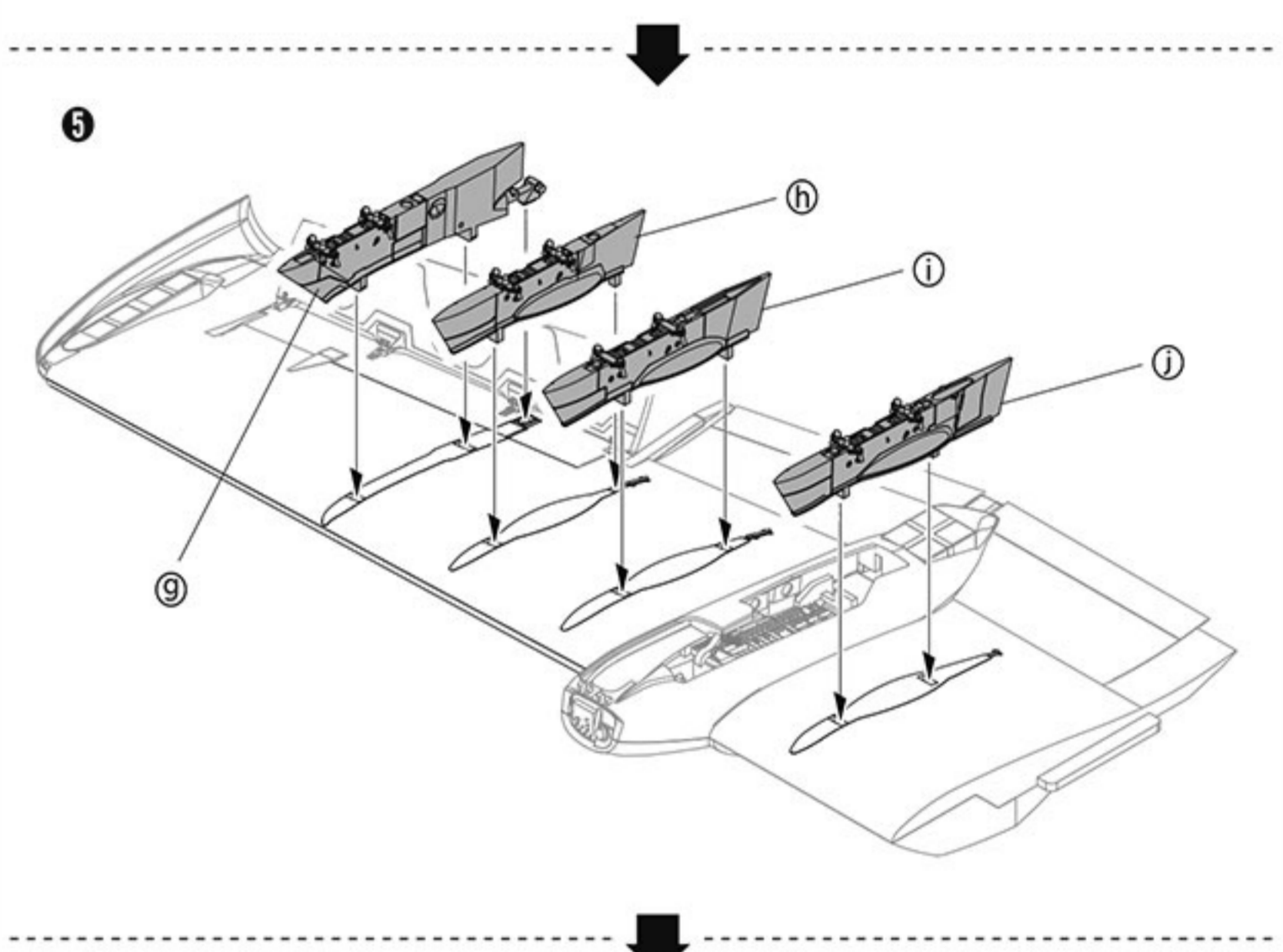
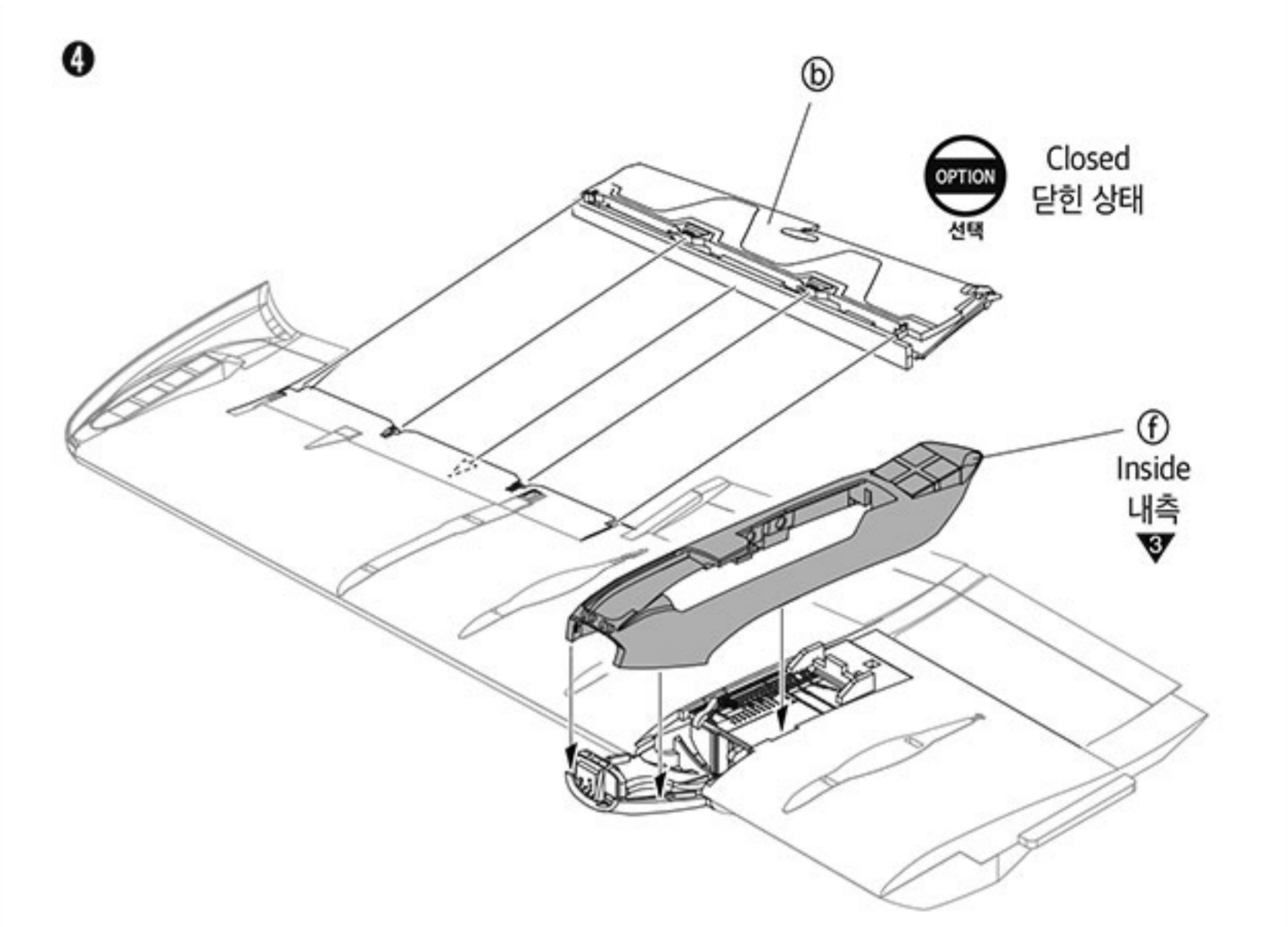
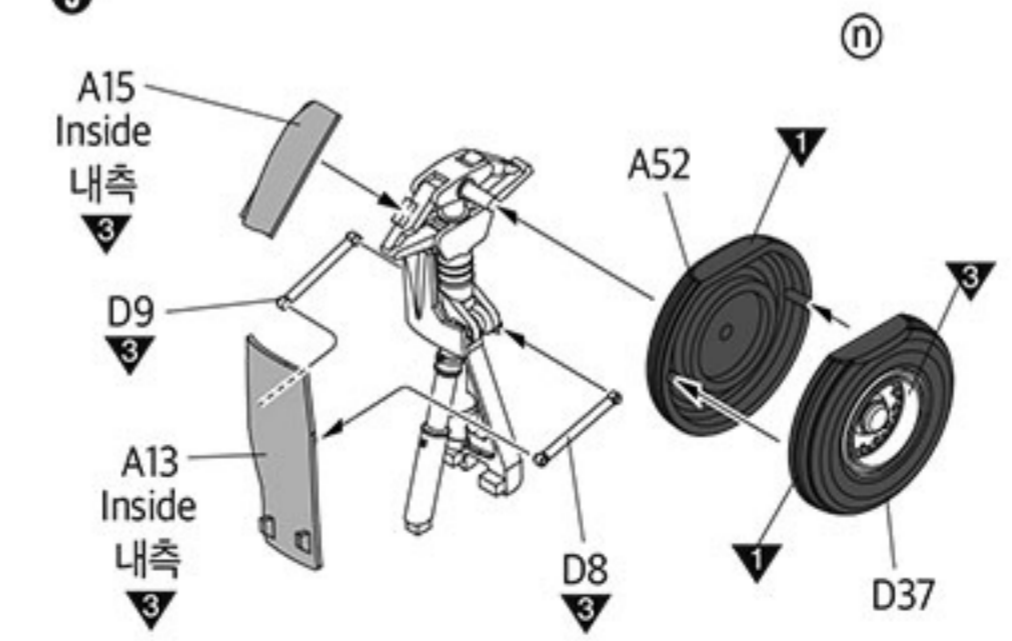
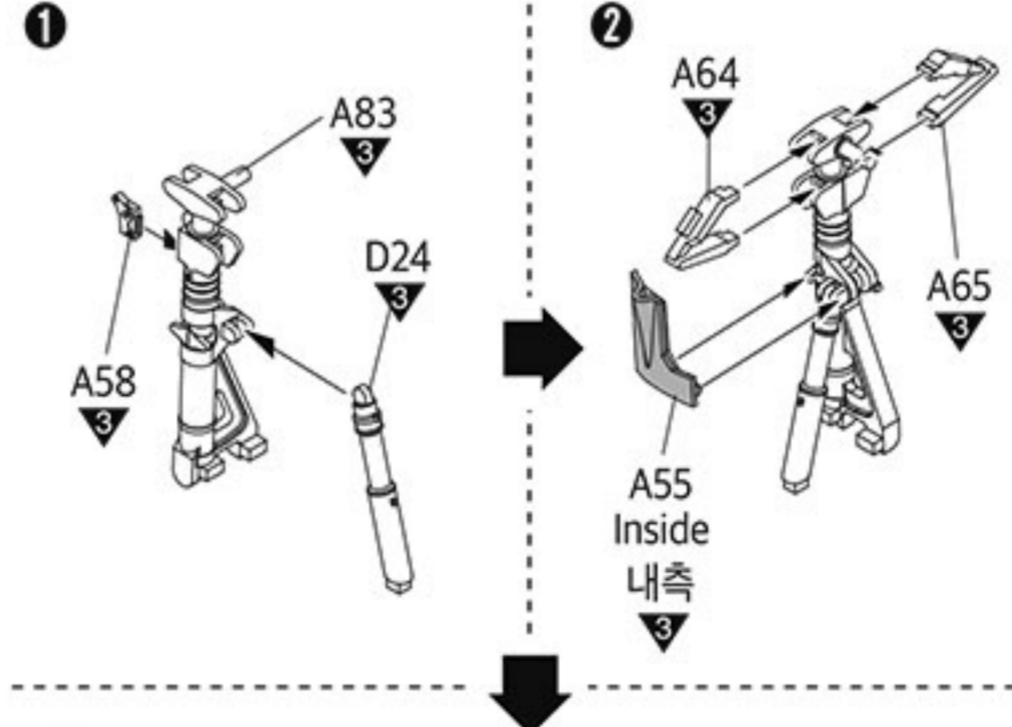
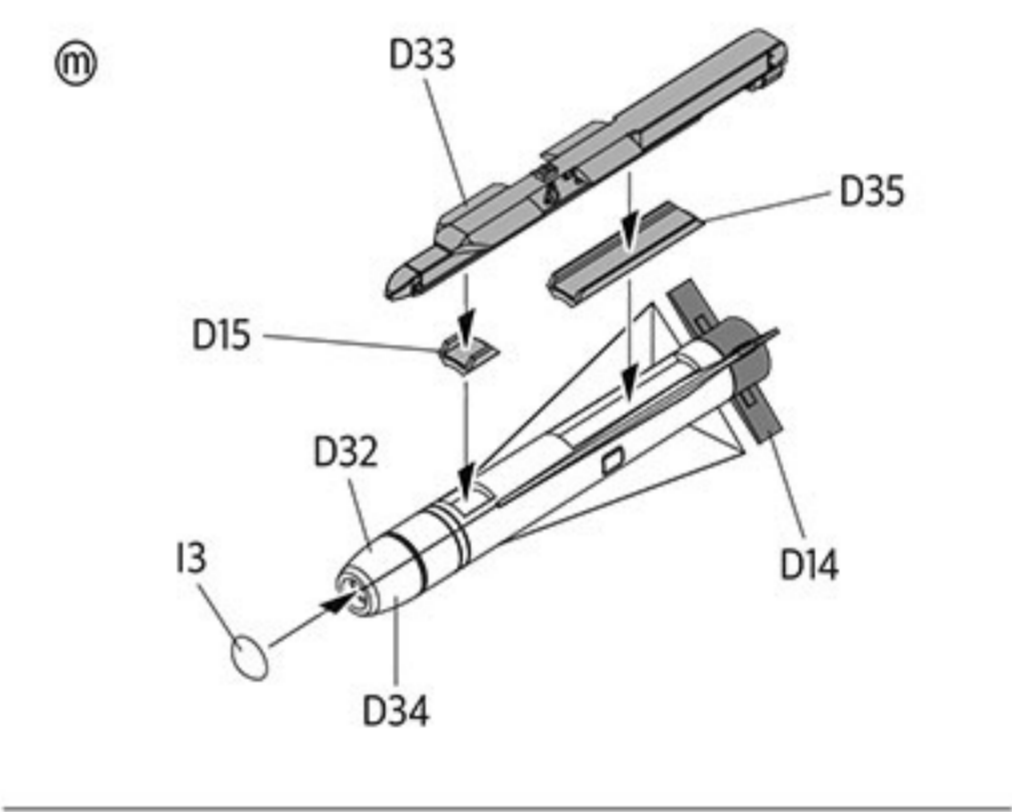
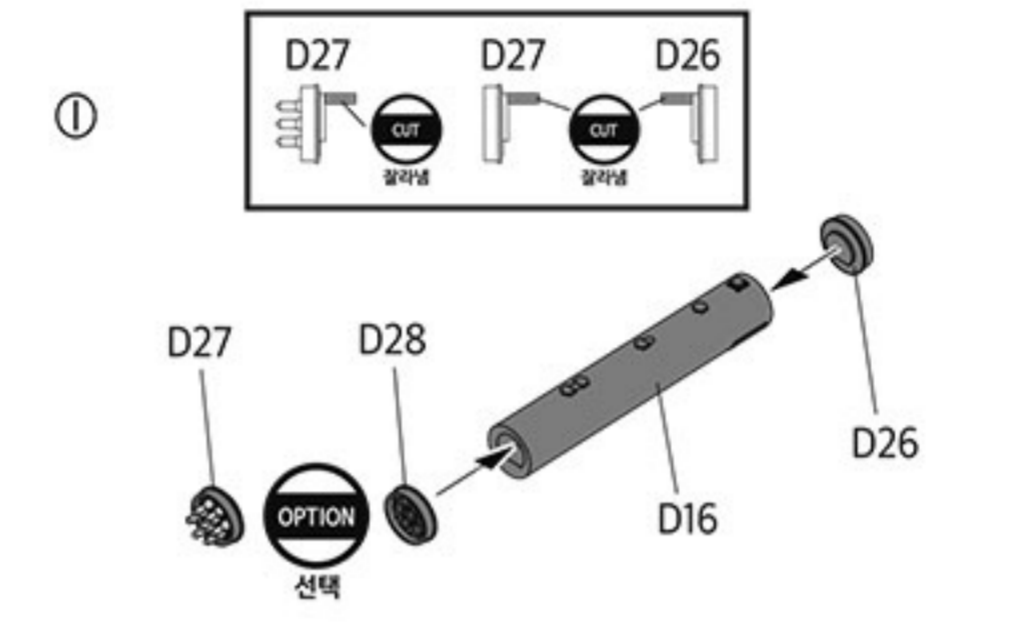
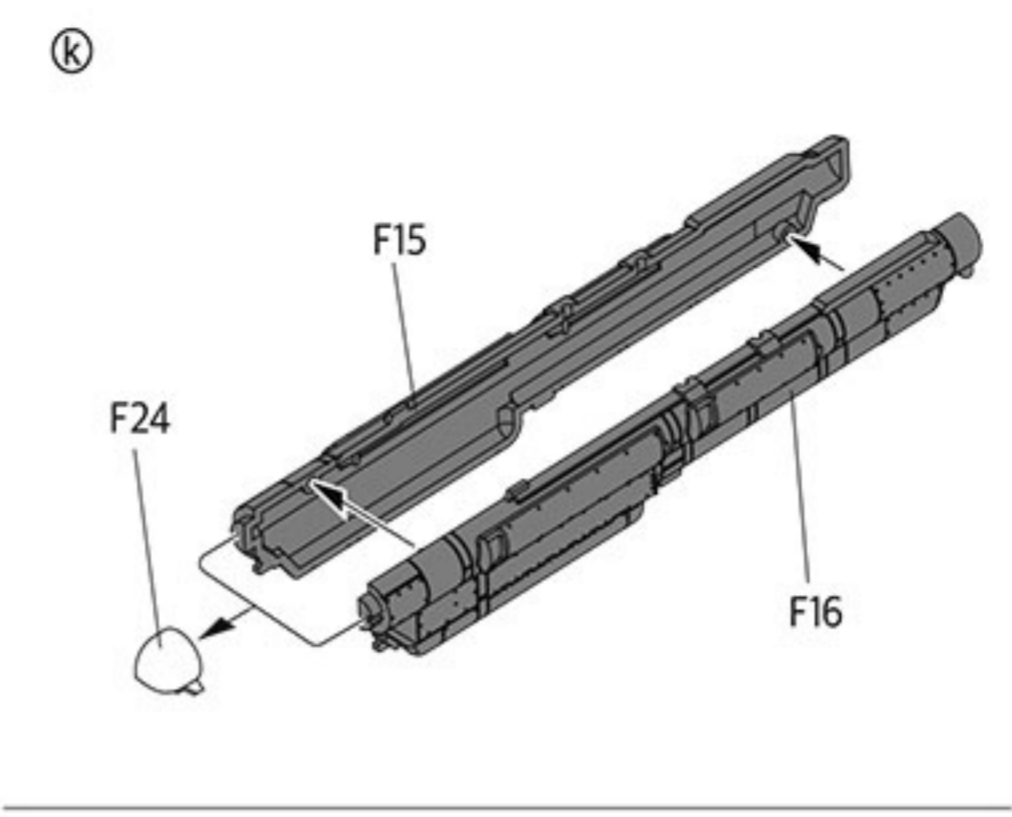
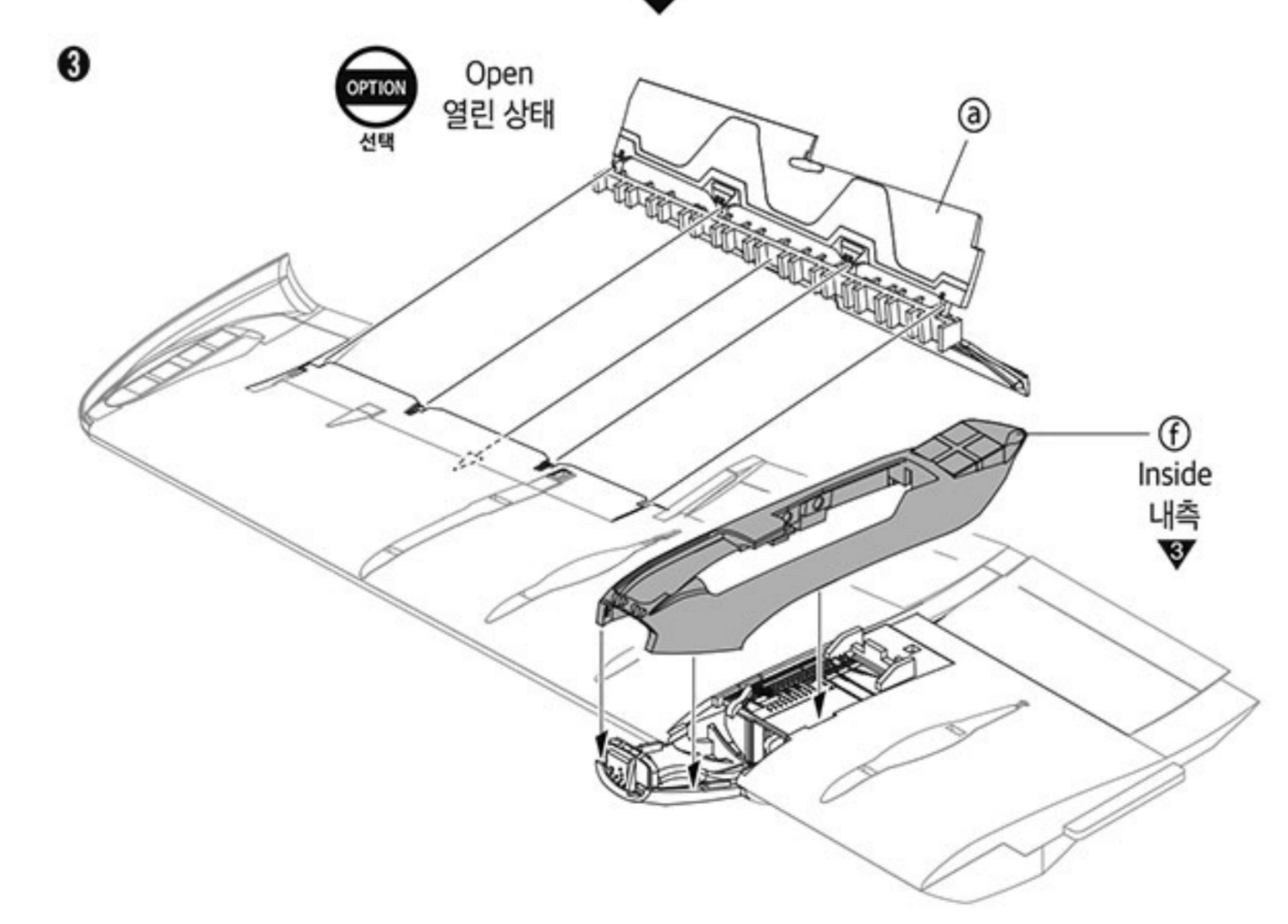
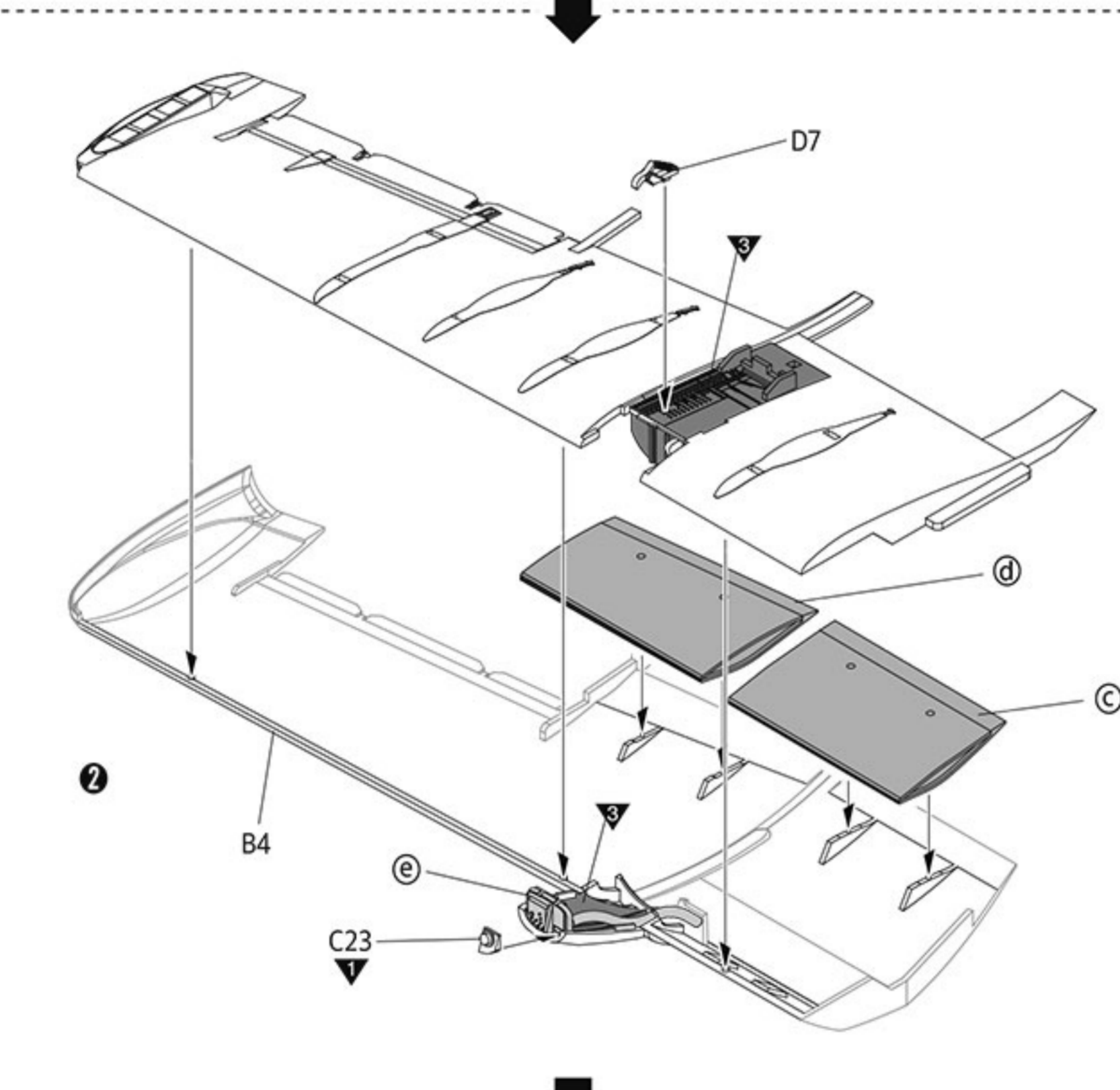
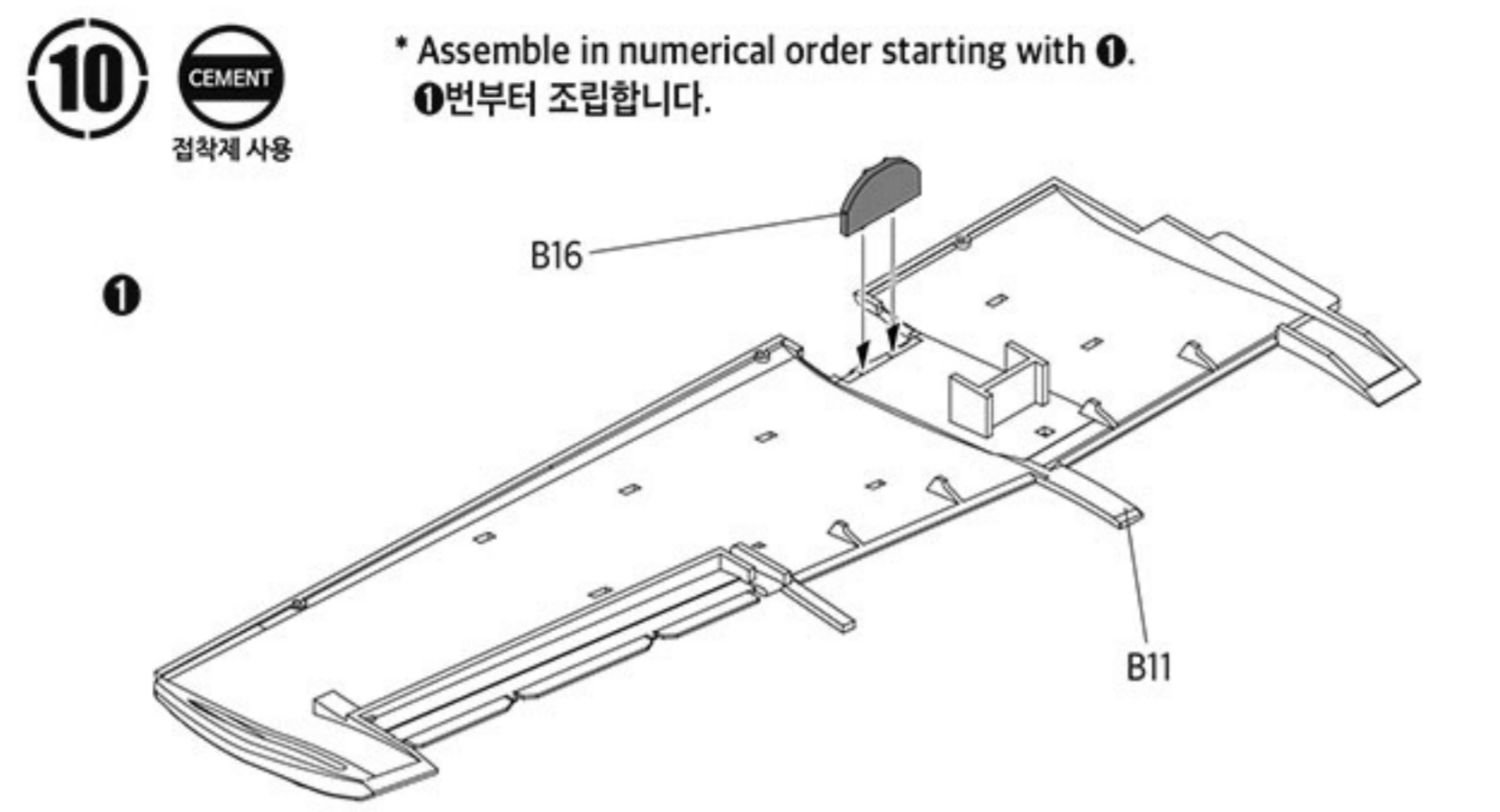
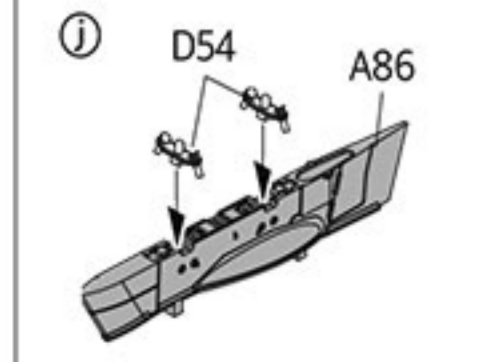
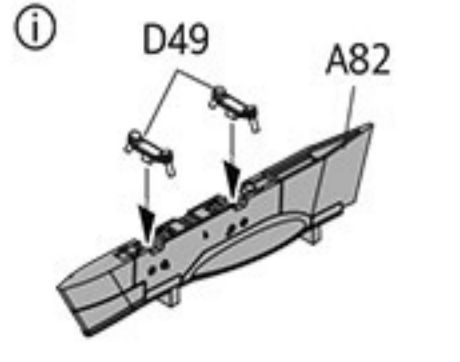
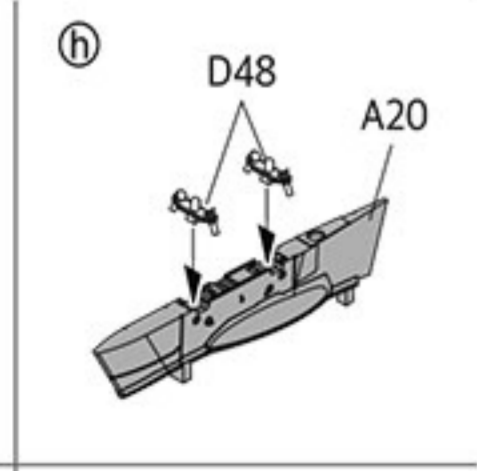
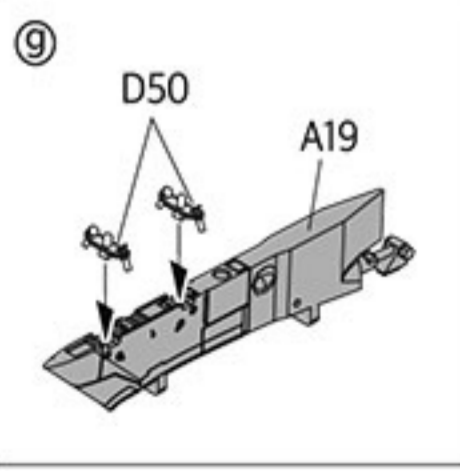
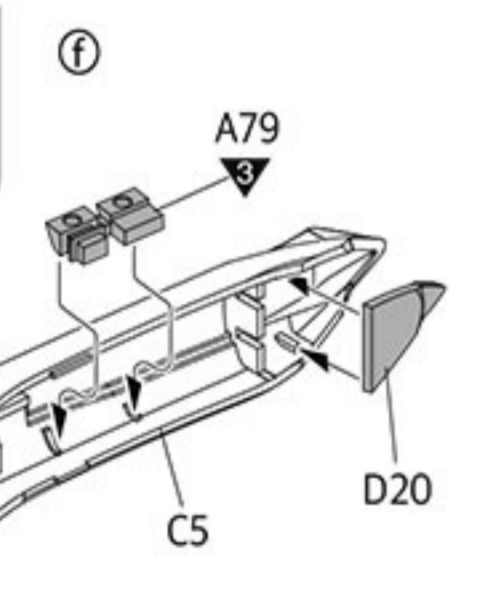
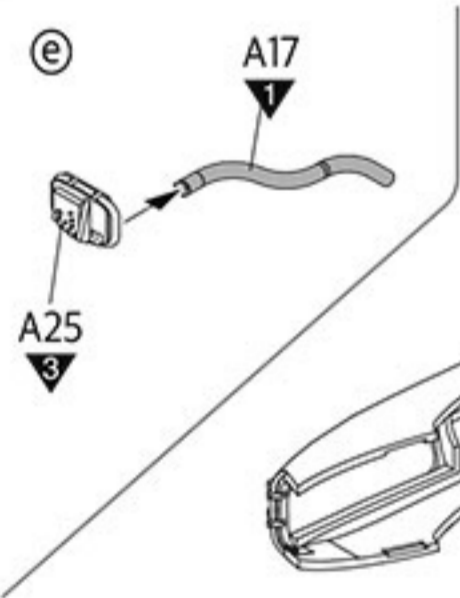
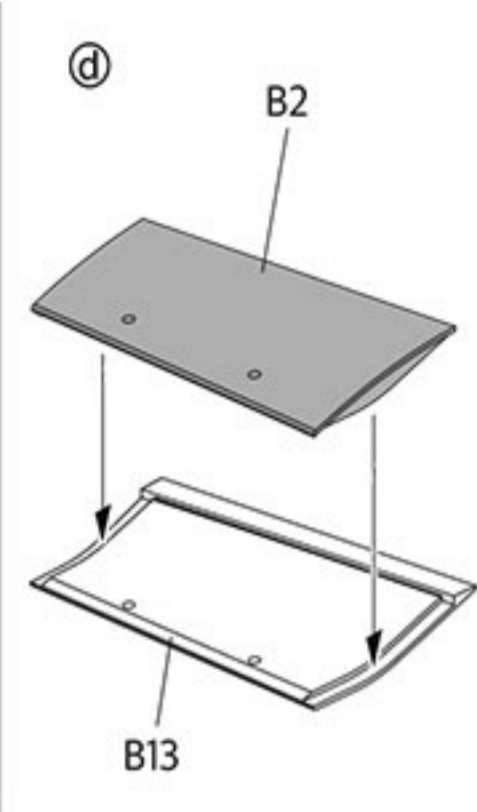
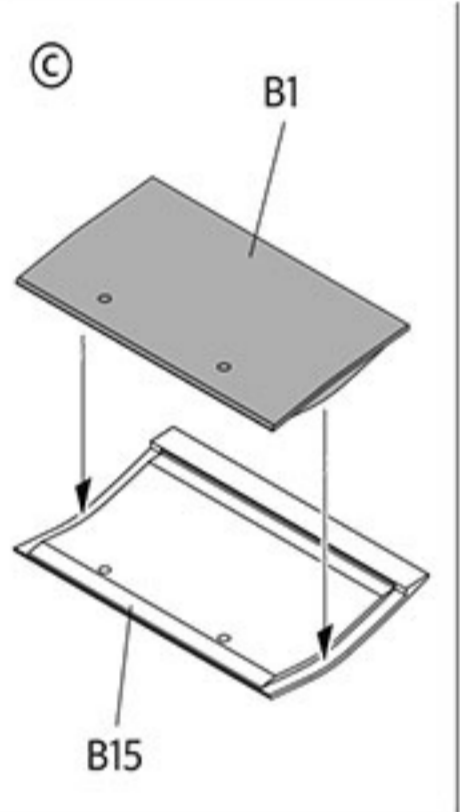
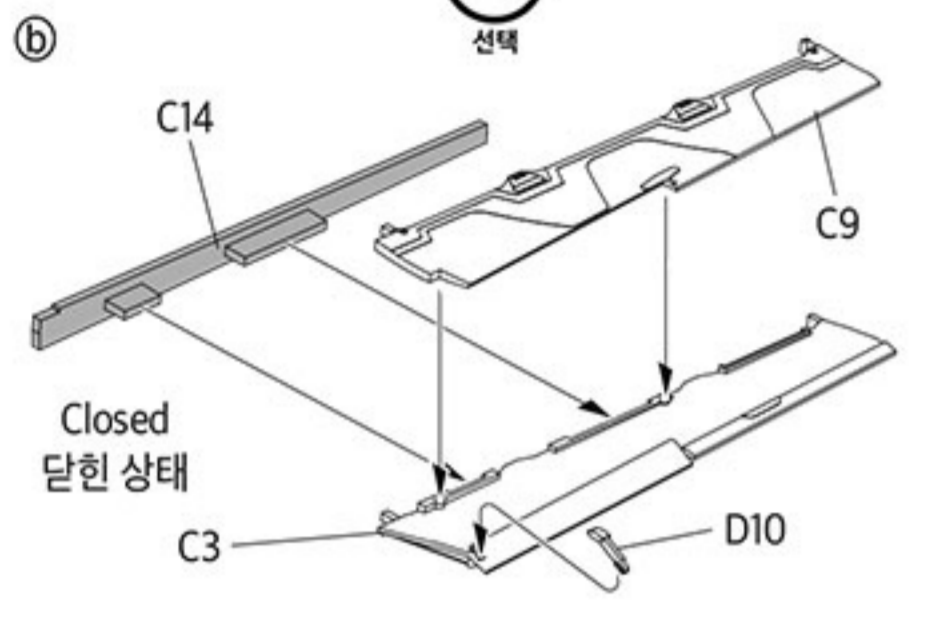
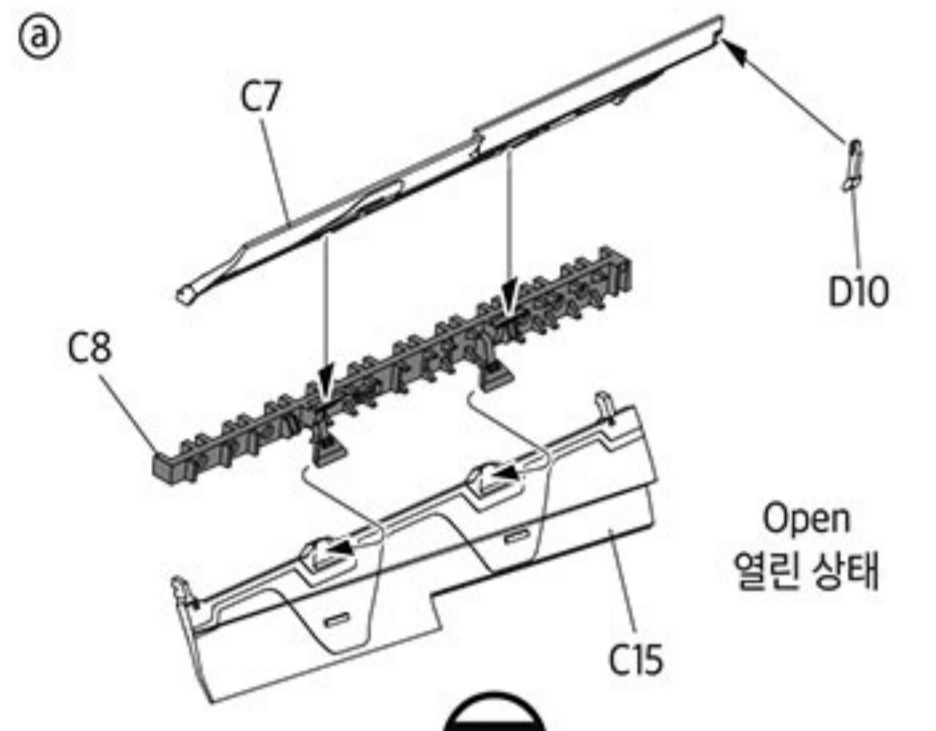

11 CEMENT
접착제 사용

*Attach 1 first.
1 먼저 조립합니다.

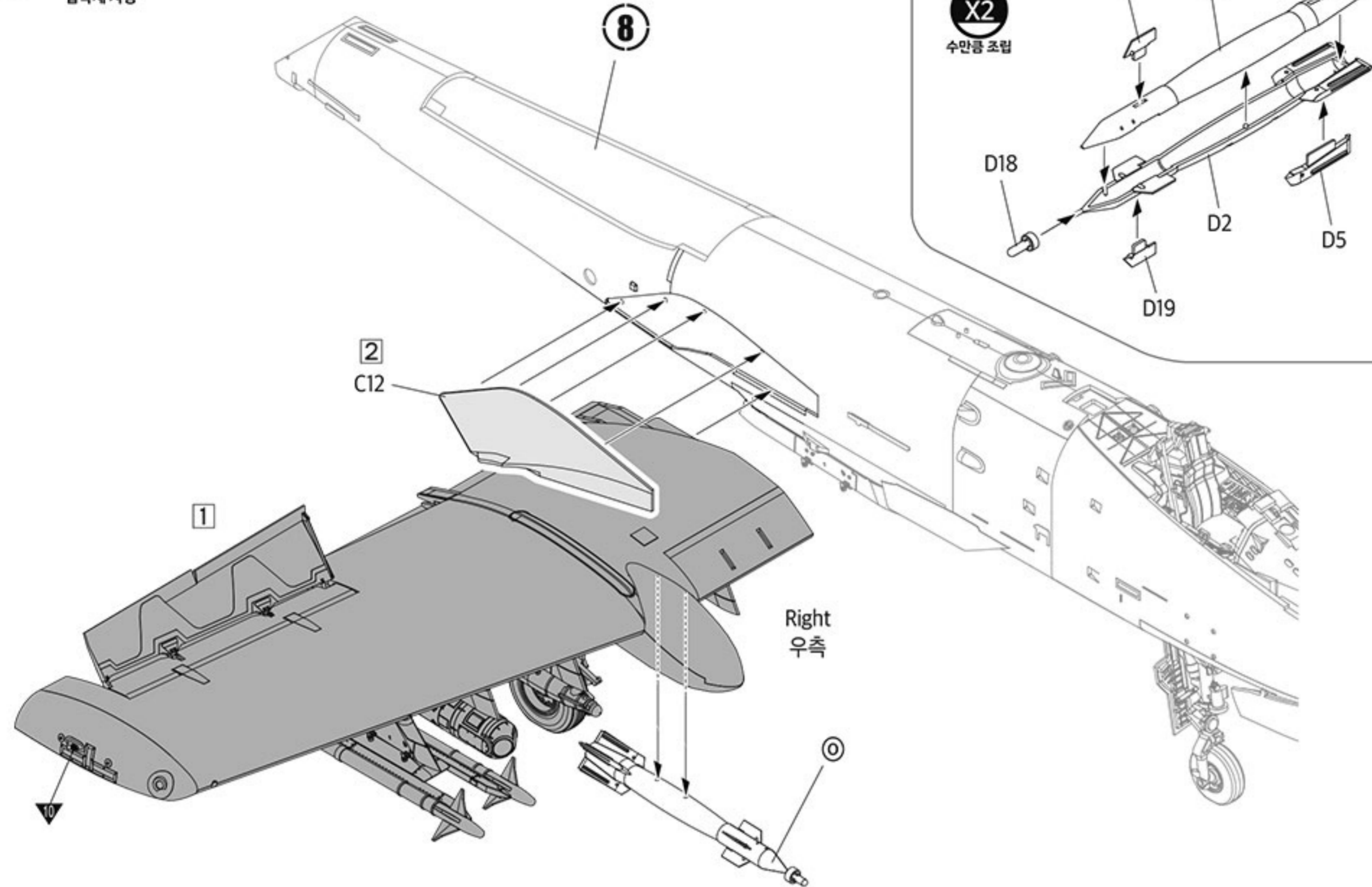

12 CEMENT
접착제 사용

*Attach 1 first.
1 먼저 조립합니다.

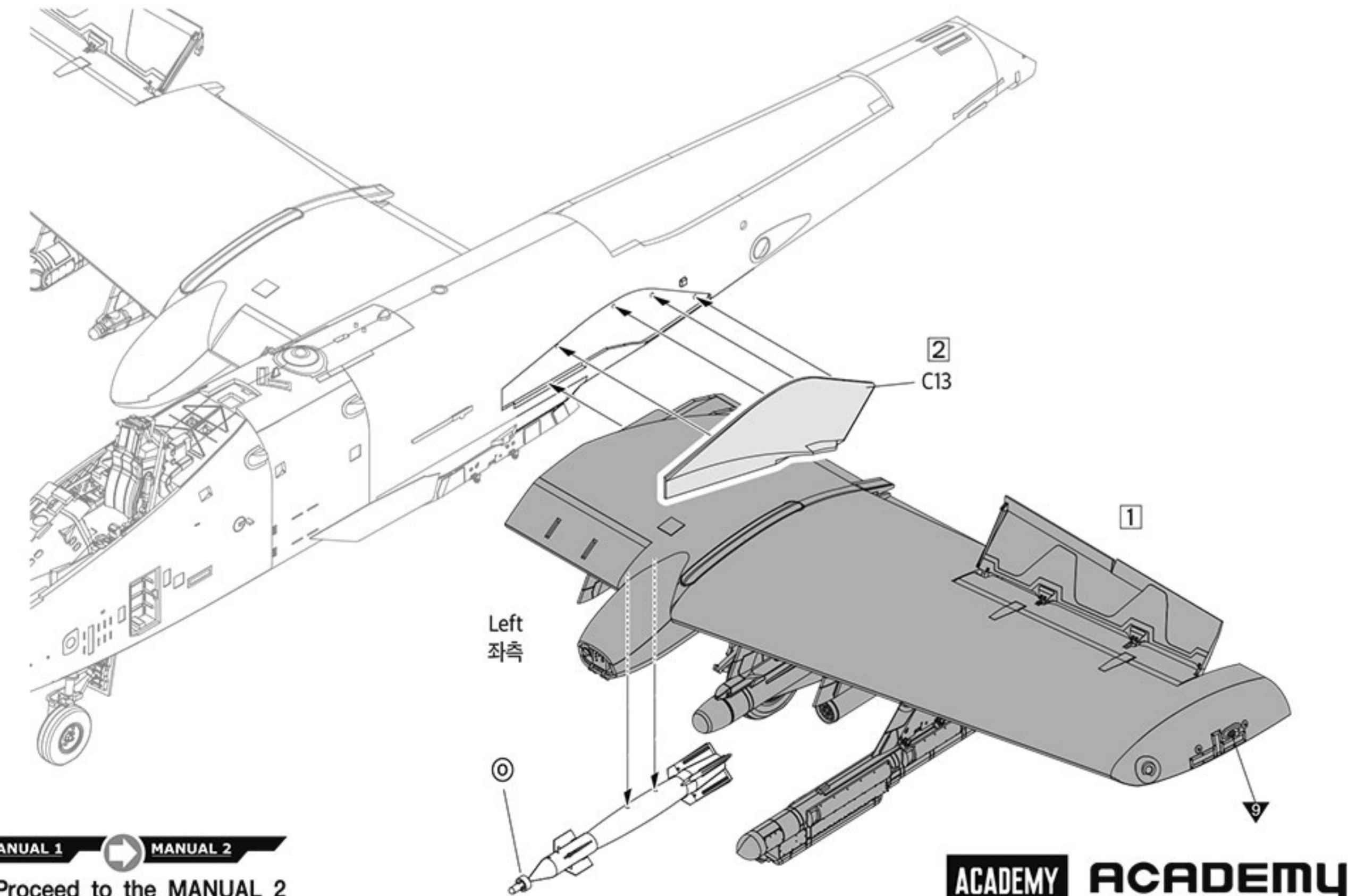

MANUAL 1 → MANUAL 2

※ Proceed to the MANUAL 2
MANUAL 2로 이어집니다.

ACADEMY
HOBBY MODEL KITS
ACADEMY
ACADEMY PLASTIC MODEL CO., LTD.
A/S 고객센터 대표 번호: 1588-2406



* You can download the latest version of an instruction manual for this model by visiting www.academyhobby.com, clicking the link for 'INSTRUCTION & DOWNLOAD' and entering the item number. 본 제품의 조립 중 궁금한 점은 www.academy.co.kr 접속 후 메뉴 '자료실' → '프라모델' 로 이동하여 해당 제품명을 입력하면 최신의 설명서를 확인 할 수 있습니다.

Warning in Assembly of Model Kits
조립전의 주의사항

Take care not to injure yourself while using the modeling tools to cut or trim parts.
공구를 이용하여 부품을 다듬고 자를 경우 손을 다치지 않도록 주의를 기울여 주십시오.



CAUTION
-주의-

- ◀Read this before you begin▶
- Study the instructions before assembling.
 - Check the fit of each piece before cementing into place.
 - Never use cement or paint near open flame.
 - Do not use too much cement to join parts.
 - Open a window or make area well ventilated when cement or paint is in use.
 - Tear up and throw away the empty plastic bags to avoid danger of suffocation for little children.
- ◀조립하기 전에▶
- 부품을 조립하기 전에 설명서를 잘 읽어본 후 조립한다.
 - 전착하기 전에 부품을 맞추어 확인한 후 조립한다.
 - 부품을 자를 때에는 칼이나 니퍼로 깨끗이 잘라준다.
 - 접착제를 사용할 곳과 사용하지 않는 곳에 주의하고 너무 많이 바르지 않도록 한다.
 - 에나멜 페인트나 접착제를 사용할 때에는 창문을 열어 환기를 시키고 화기를 멀리한다.
 - 사용 후 남은 부품은 어린이의 손에 닿지 않도록 잘 처리한다.

CEMENT 접착제	CEMENT 접착제 금지	X2 수만큼 조립	DECAL 전사지	BALLAST 무게추	PE 애칭	FILL 채움
CUT 잘라냄	OPTION 선택	OPPOSITE 반대측	HOLE 뚫어줌	CAUTION 주의	INSTANT CEMENT 순간 접착제	VER.1 버전

PAINT INDEX	Humbrol		GSI Creos		Lifecolor	Testor / Model Master		Revell		Vallejo		AK Inter-active	MAIN COLOR
	Enamel	Acryl	Aqueous Hobby Color	Mr.Color		Enamel	Acryl	Enamel	Acryl	Model Color	Model Air		
1 FLAT BLACK FS 37038	33	33	H12	33	LC02	1749	4768	32108	36108	950	57	735	무광 검은색
2 DARK GULL GRAY FS 36231	140		H317	317	UA033	1740	4755	32179	36179	991		2304	다크 걸 그레이
3 WHITE FS 17875	22	22	H316	316	LC51	1745	4696	32104	36104	842		4237	흰색
4 STEEL	53	53	H18	28	LC76	1795	4681	32191	36191	863	72	798	스틸
5 SILVER	11	11	H8	8	LC74	2914	4678	32190	36190	997	63	139	은색
6 DARK GHOST GRAY FS 36320	128	128	H307	307	UA027	1741	4761	32374	36374	905	47	2058	다크 고스트 그레이
7 LIGHT GHOST GRAY FS 36375	127	127	H308	308	UA026	1728	4762	32143	36143	989	50	2057	라이트 고스트 그레이
8 BURNT IRON			H76	61									번트 아이언
9 CLEAR RED	1321		H90	47			4630			934			투명 빨간색
10 CLEAR BLUE	1320		H93	50			4658			938			투명 파란색
11 OLIVE DRAB FS34087	155		H52	12	UA005	1711	4728			887	16	4212	올리브 드랍
12 KHAKI GREEN			H80	54								4214	카키 그린
13 KHAKI	26	26	H81	55	UA304	1704	4711	32189	36189	879	23	3041	카키
14 GREEN FS34102			H302	302									초록색
15 DARK GREEN FS34092	30		H73	23				32165		892	13		다크 그린
16 GUNSHIP GRAY FS 36118	125	125	H305	305	UA022	1723	4752			867	52		건십 그레이

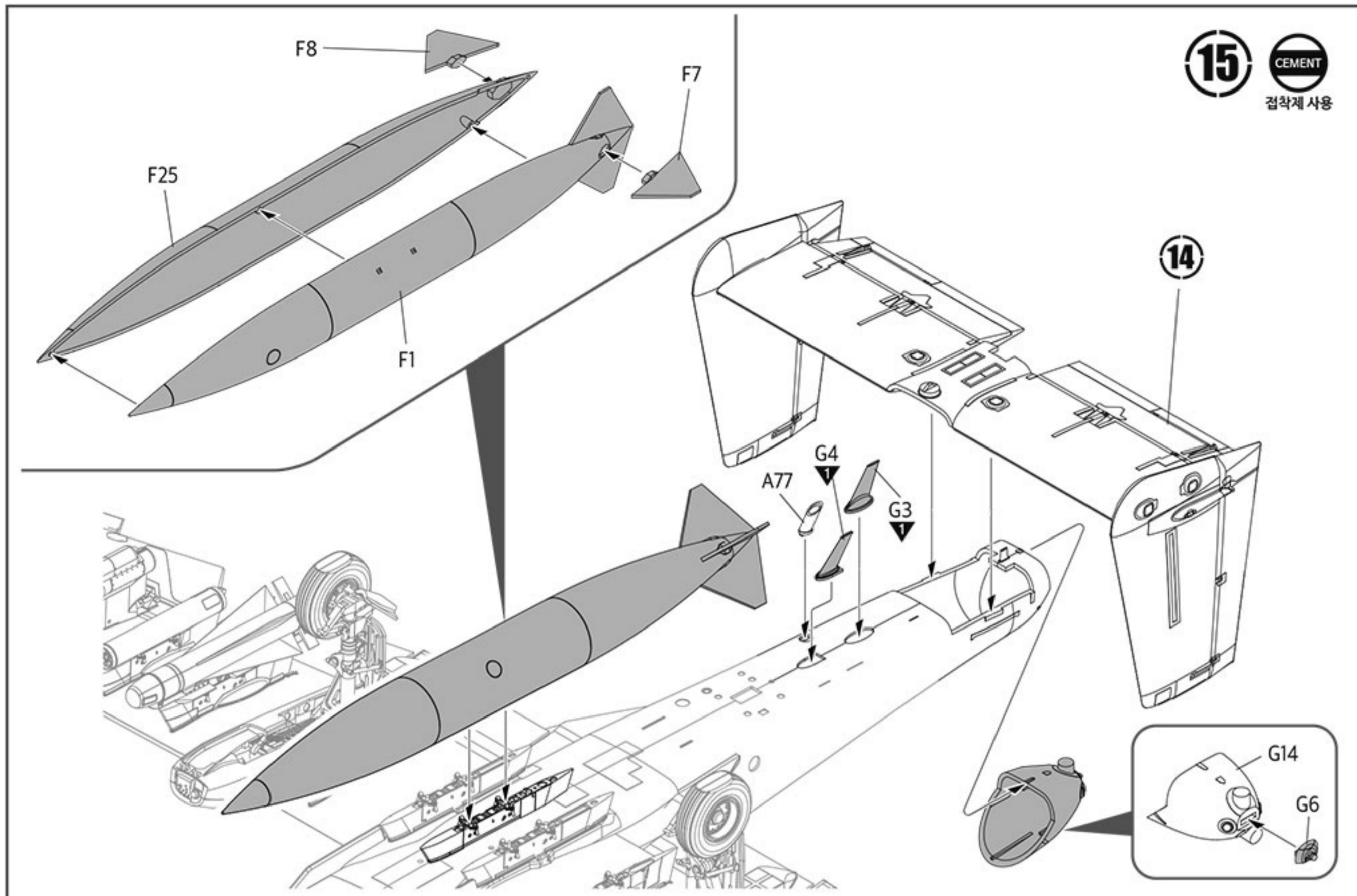

16 CEMENT
점착제 사용

* Assemble in numerical order starting with ①.
①번부터 조립합니다.

Engine cover
엔진 커버

Reference
참고

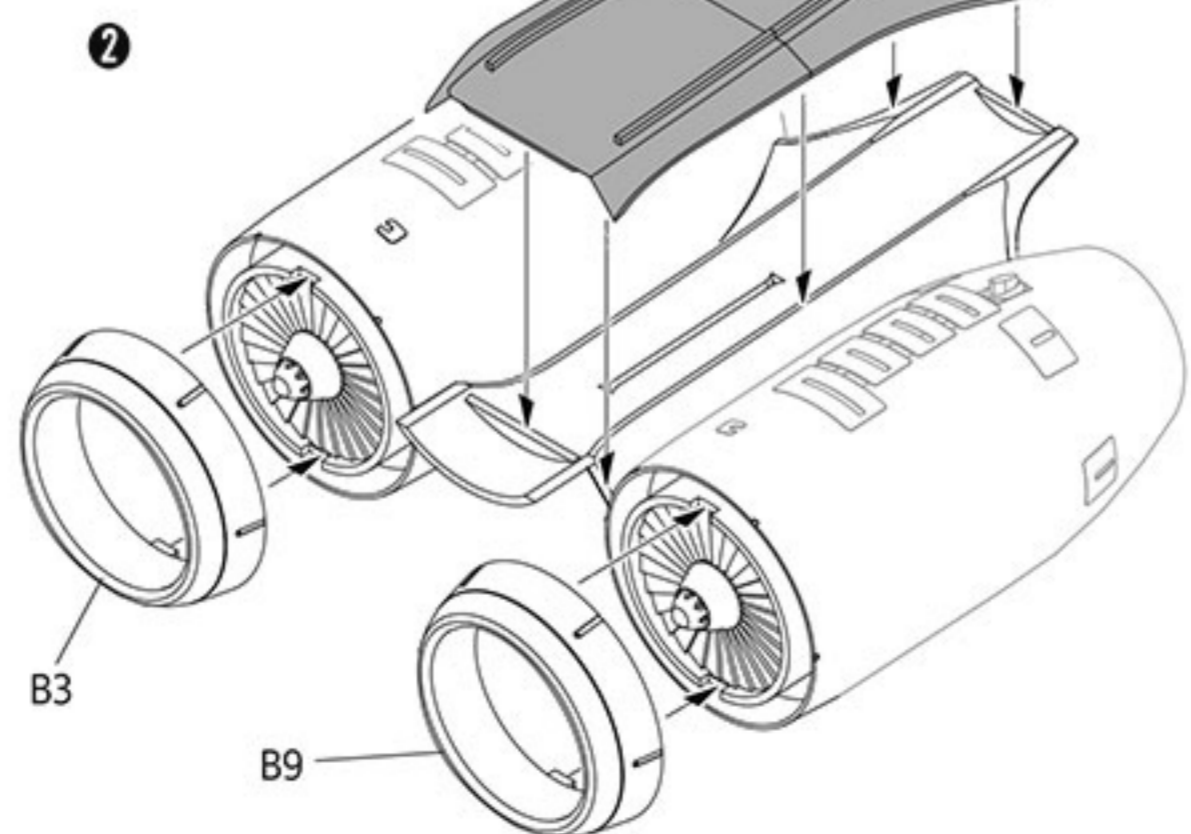
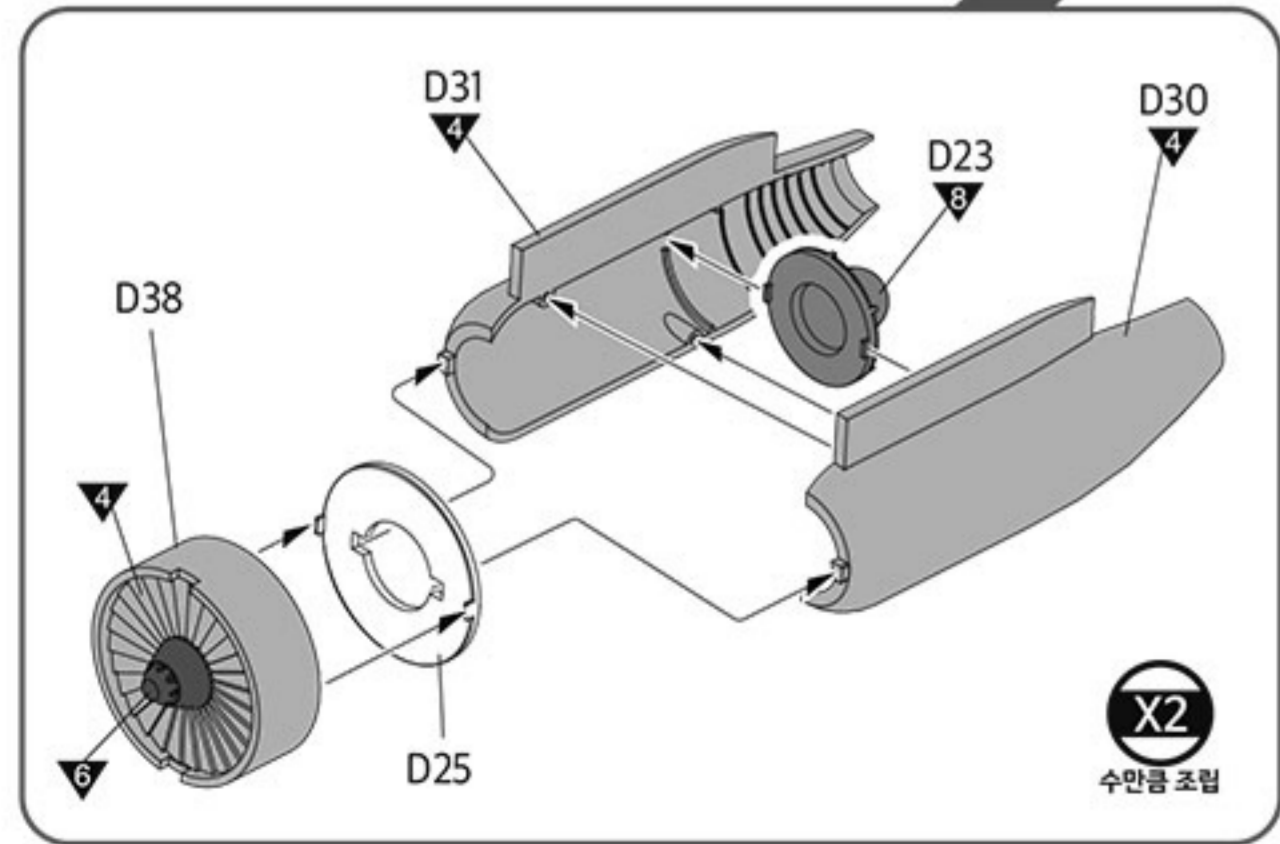
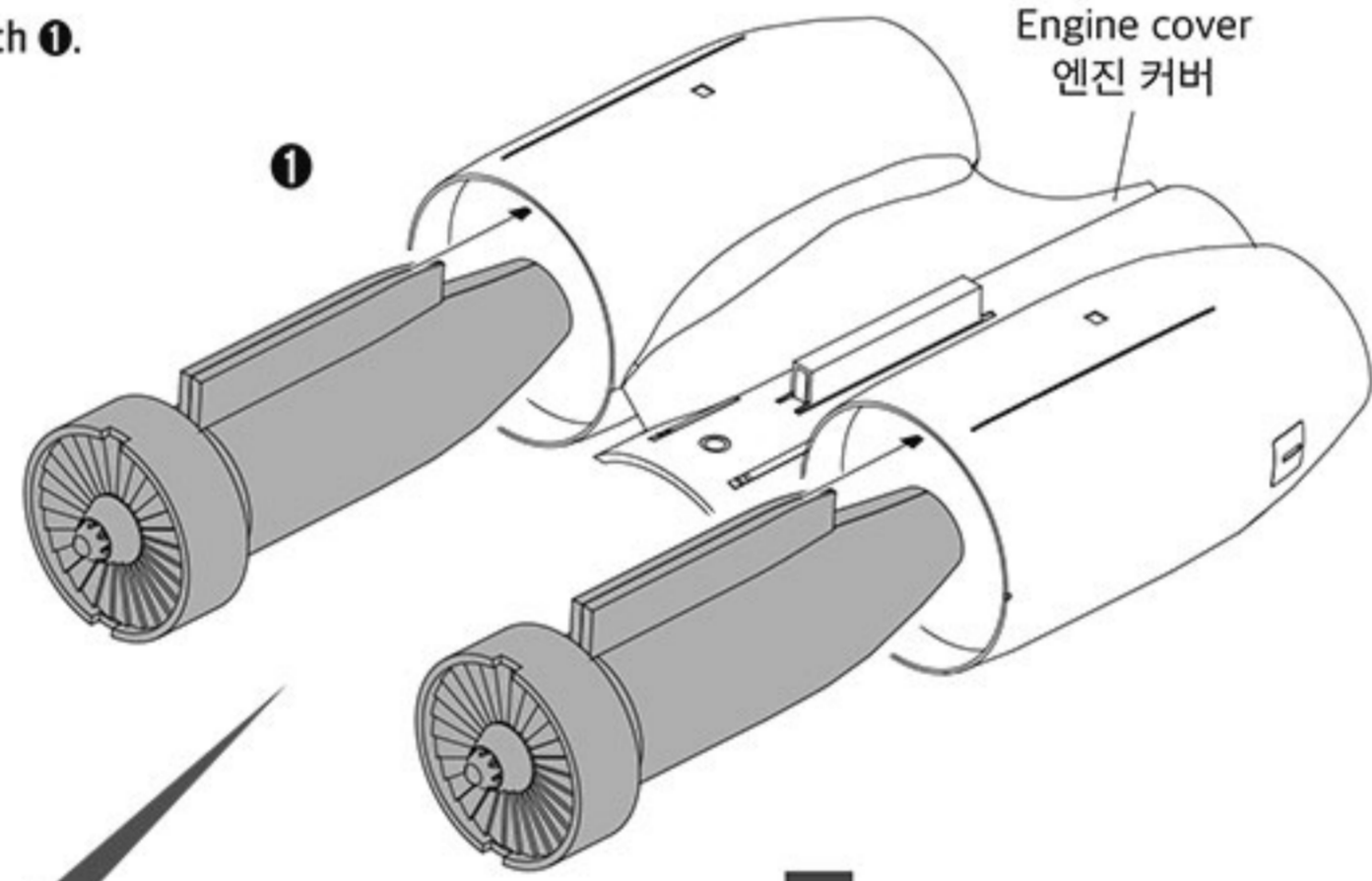
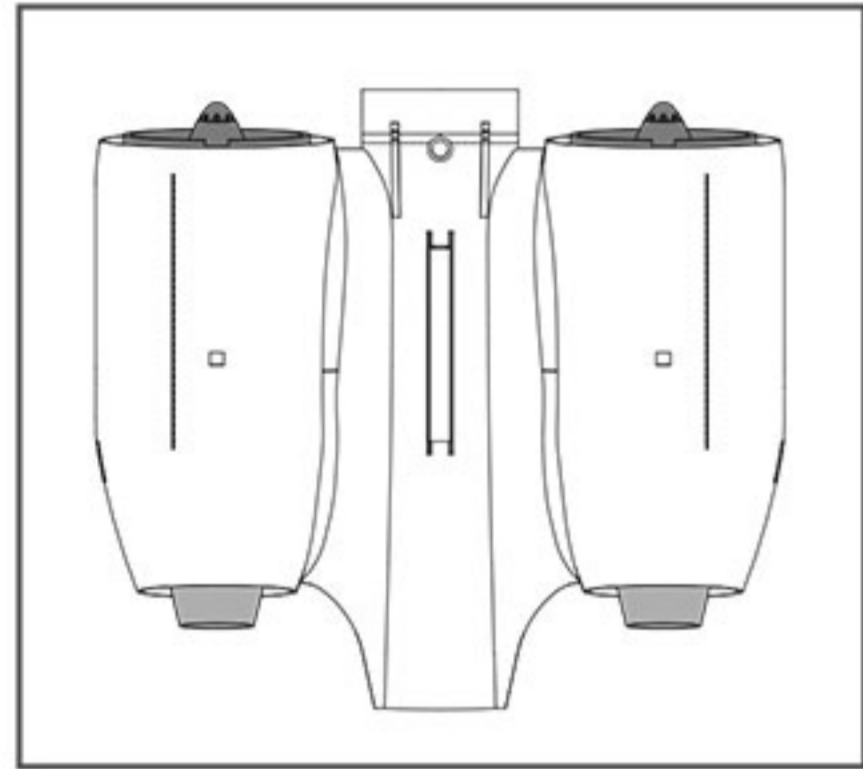

17 CEMENT
점착제 사용

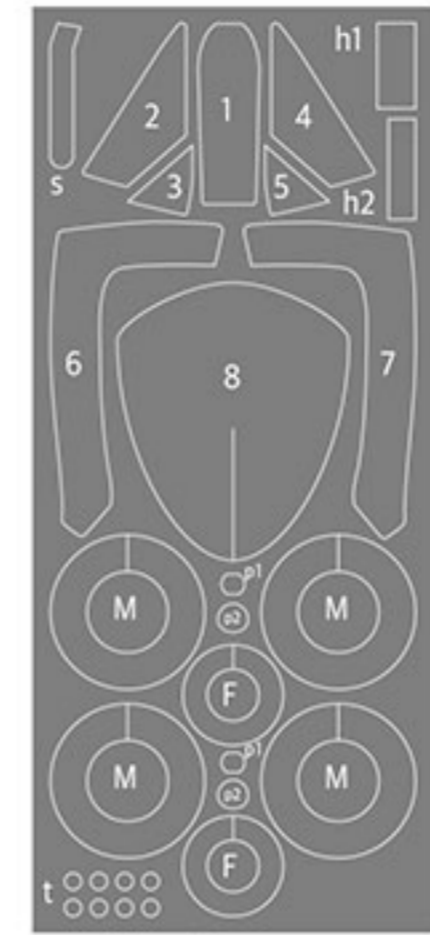

Masking tape
마스킹 테이프

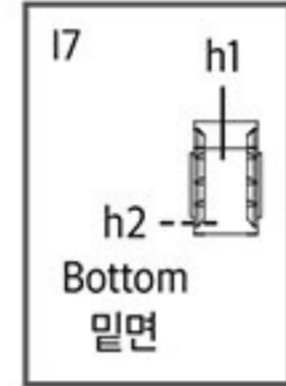

18 CEMENT
점착제 사용

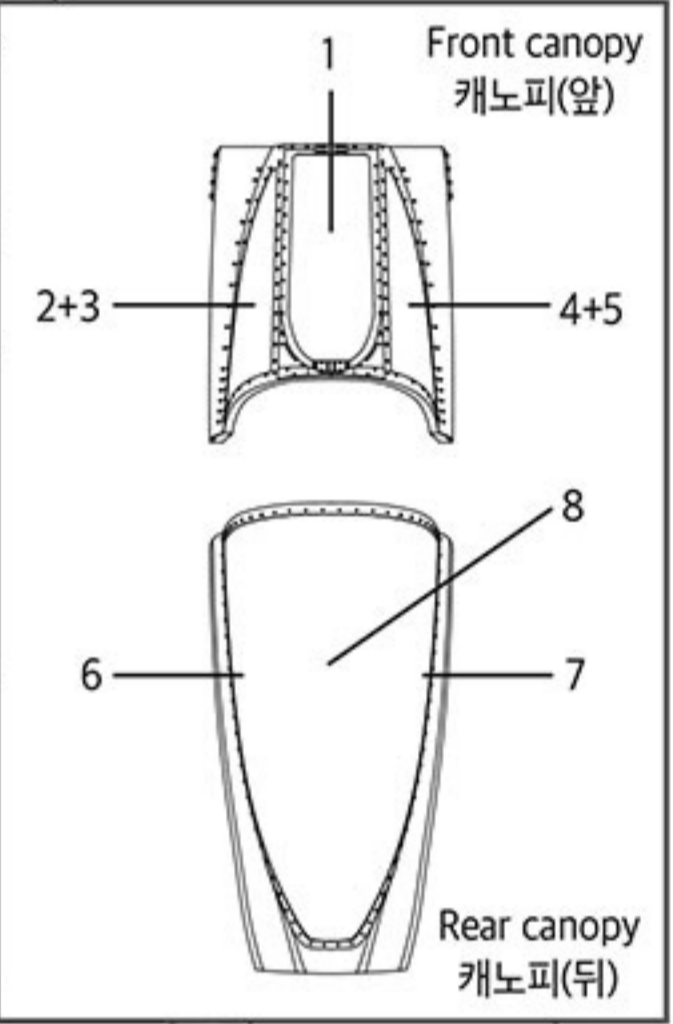
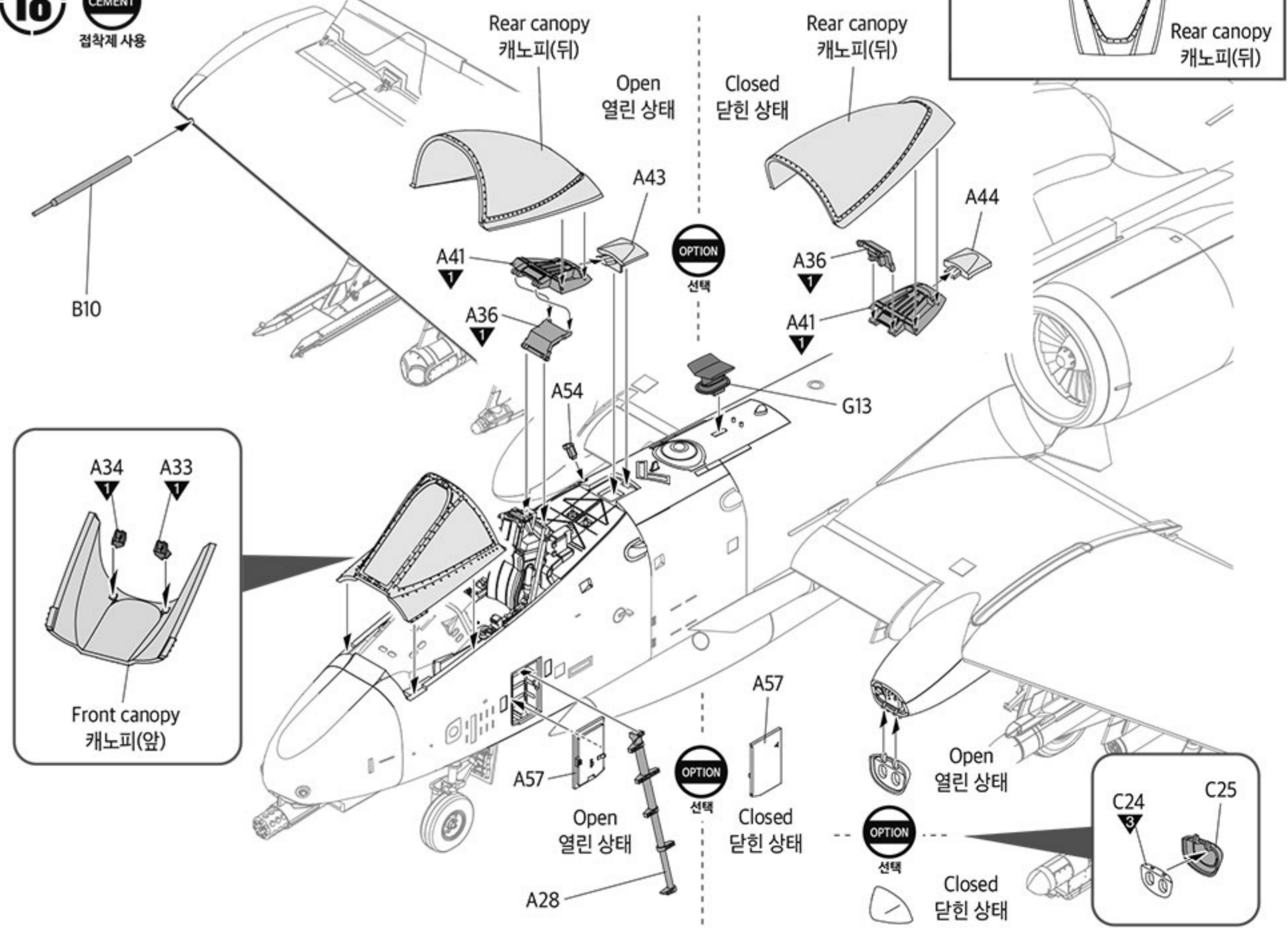

*Common data
공통 데이터

* () is opposite number.
()는 반대편 번호입니다.

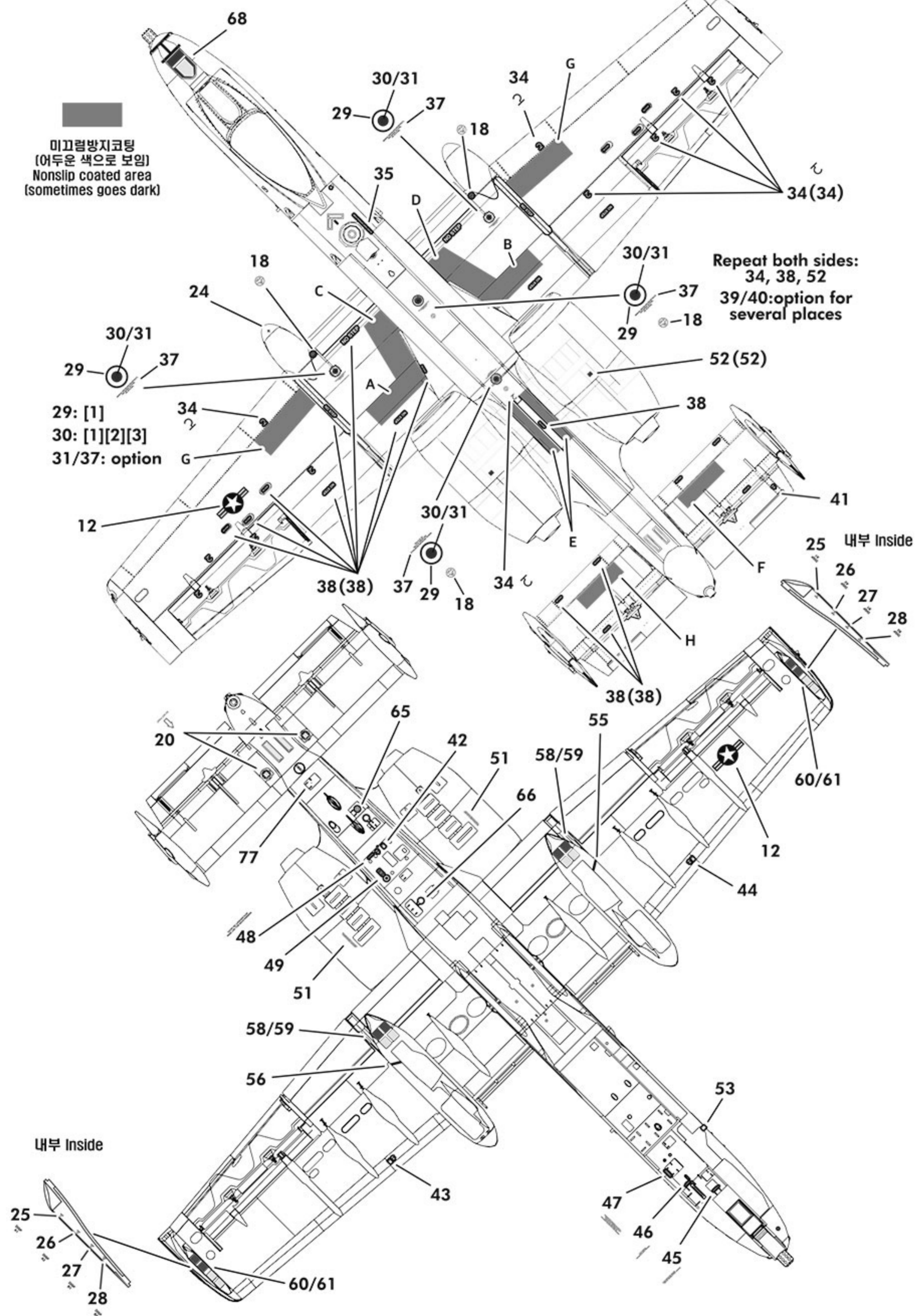

*Common data
공통 데이터

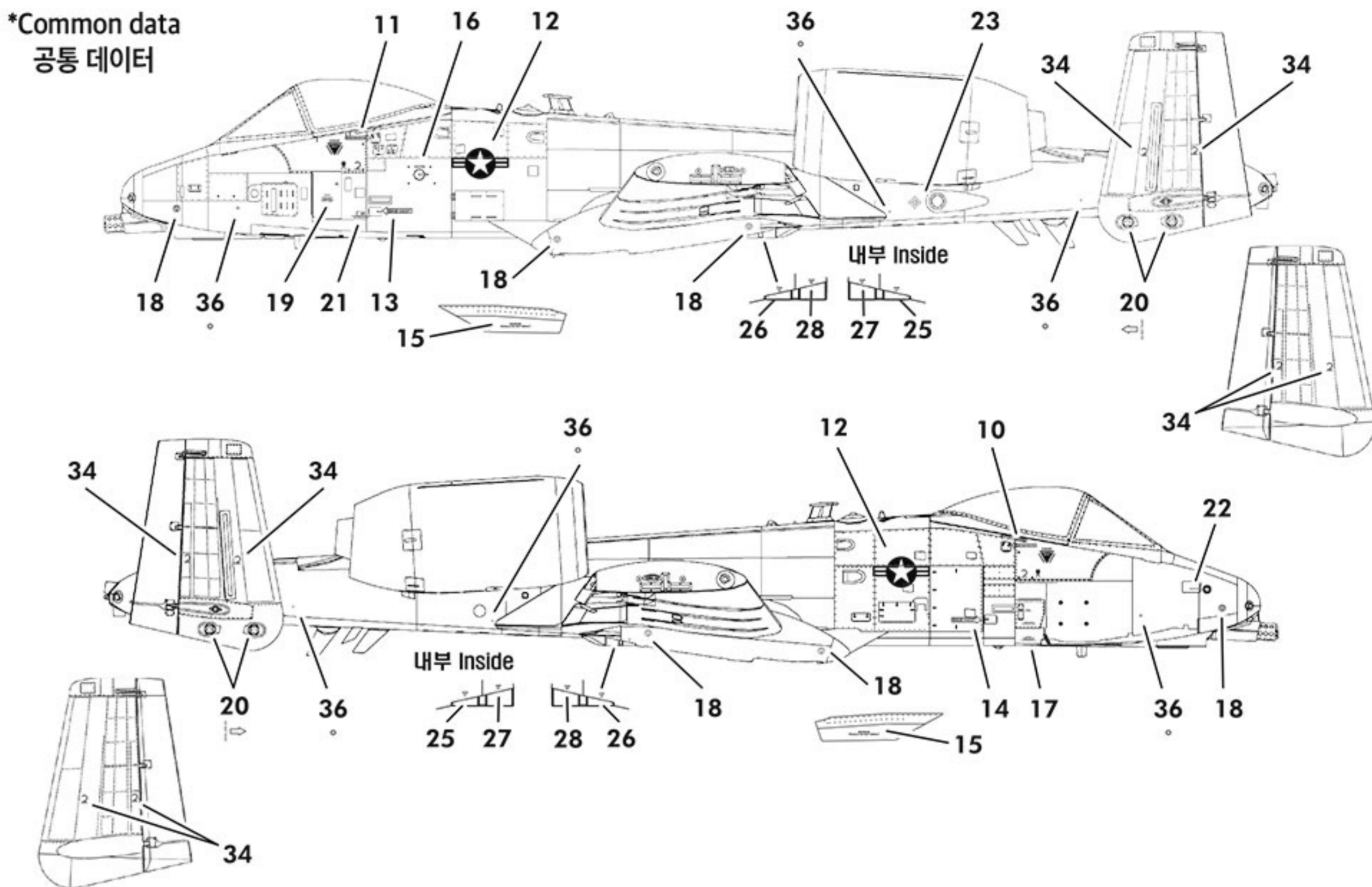

Front landing
랜딩기어(앞)



Rear landing
랜딩기어(뒤)
Left
좌측

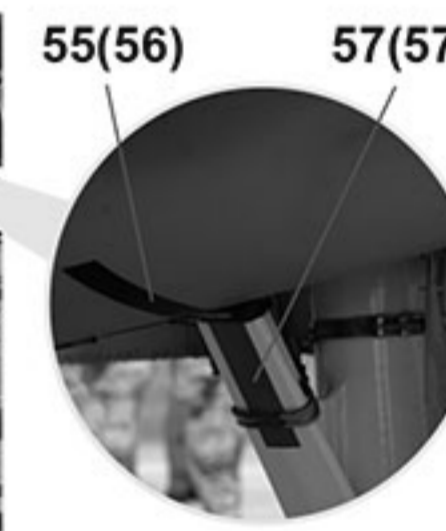

* () is right number.
()는 우측 번호입니다.

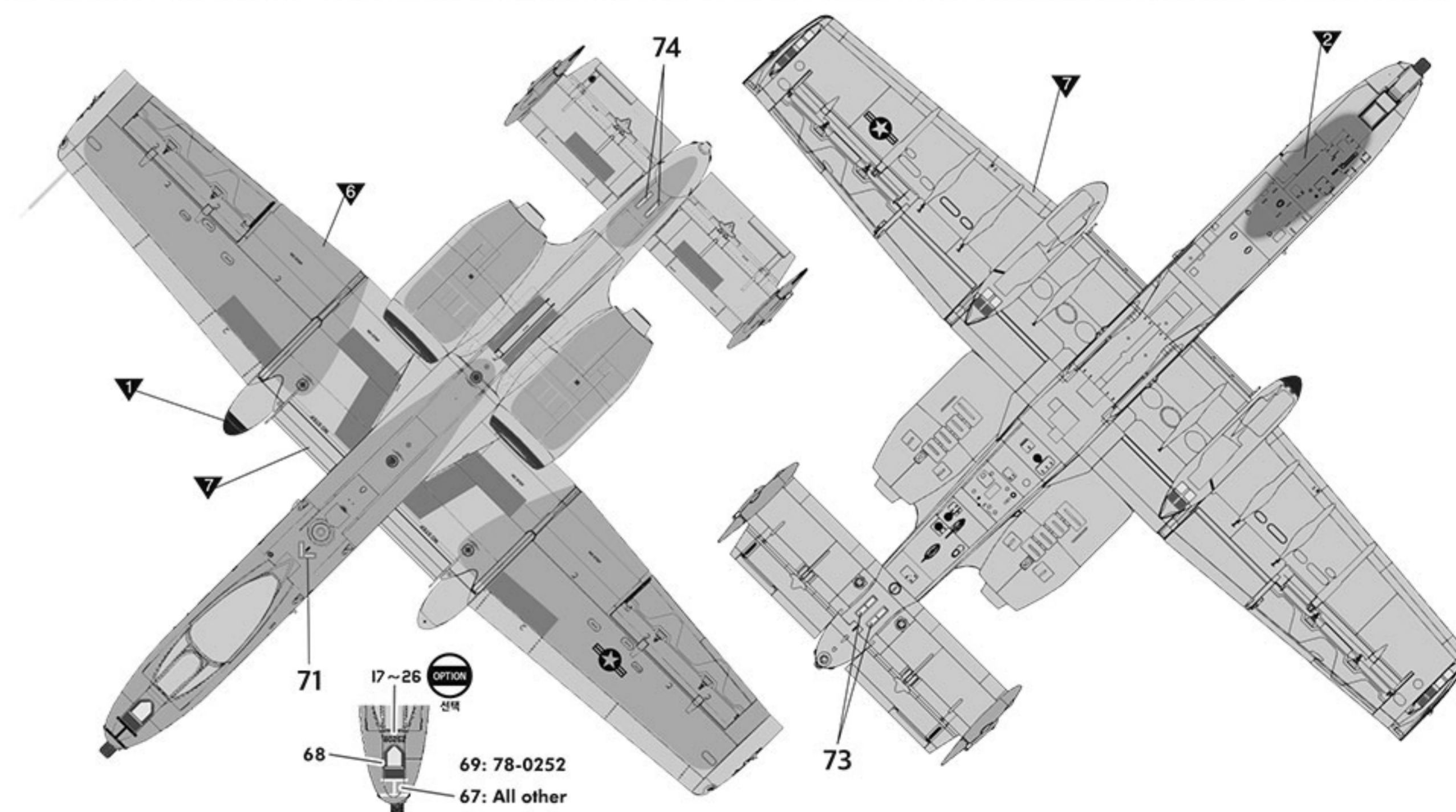

ver.1 2014년 아프가니스탄 바그람기지에 배치된 제455 원정비행단 제75 원정전투비행대 소속 A-10C, A-10Cs of 75th EFS/455th AEW, Bagram AB, Afghanistan, 2014.

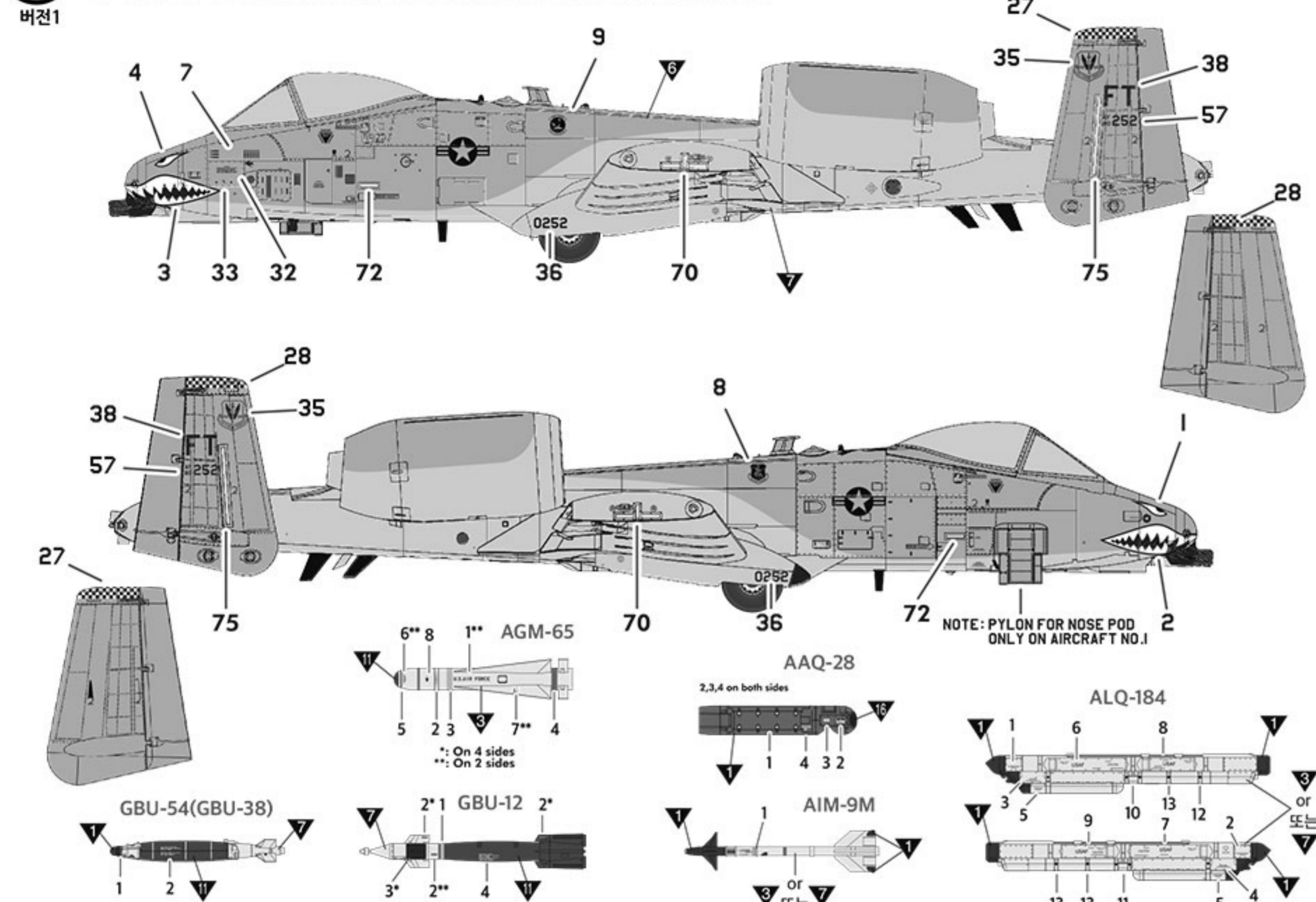

ver.2 제23비행단 제75전투비행대 소속 A-10C / A-10Cs of 75th FS, 23rd FG

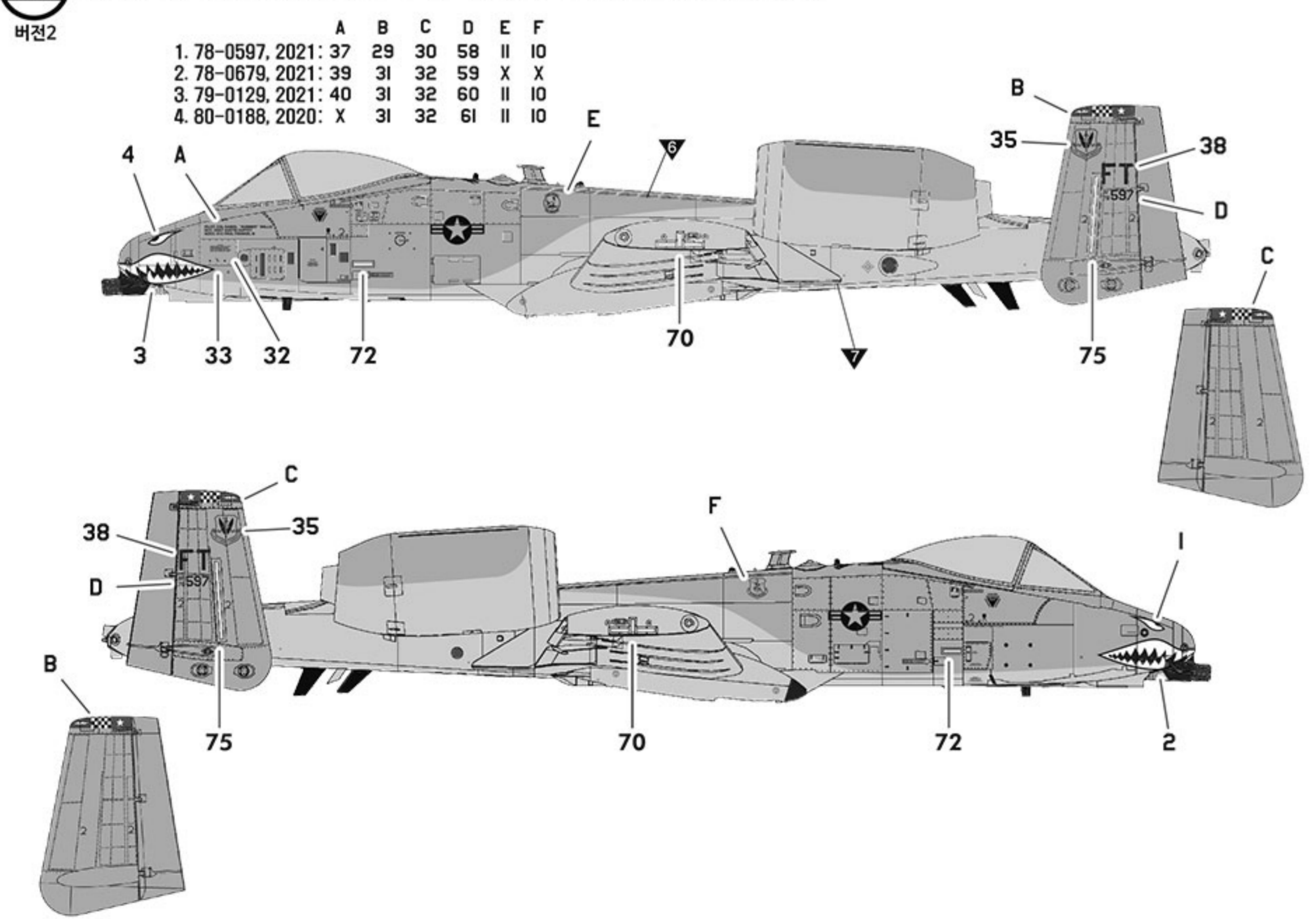

ver.3 2017년 제23전투비행단 "플라잉 타이거즈" 의 역사를 기념하는 특별도장기. 제75전투비행대 소속. A-10C 78-0597, 75th FS "Tiger Sharks" in heritage painting honoring 23rd FG "Flying Tigers", 2017.

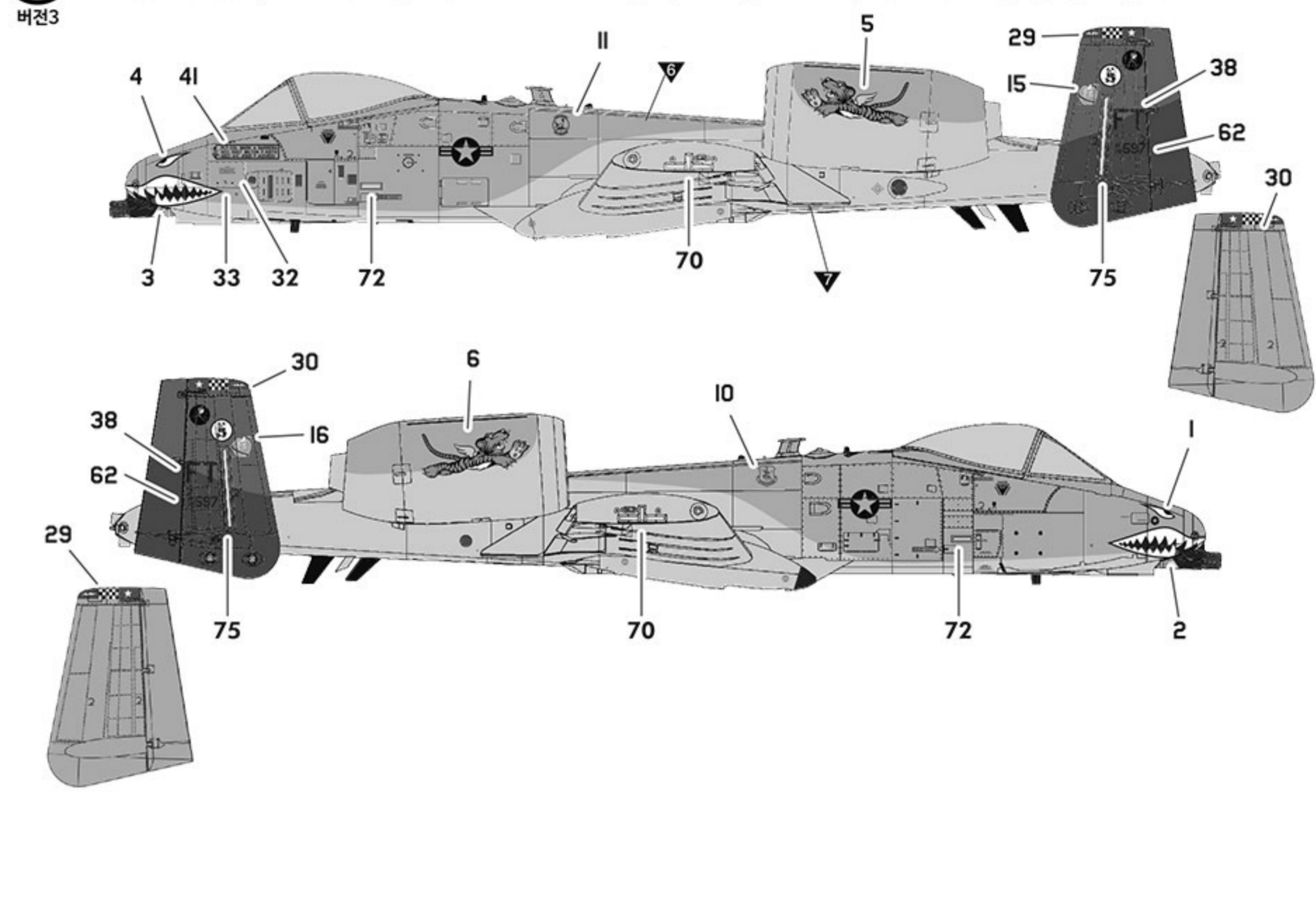

ver.4 오산기지 주둔 미공군 제51전투비행단 제25전투비행대 "Assam Draggins" 소속 A-10C, 2021/2년. A-10Cs of 25th FS "Assam Draggins", 51st FW, Osan Airbase, South Korea, 2021/2.

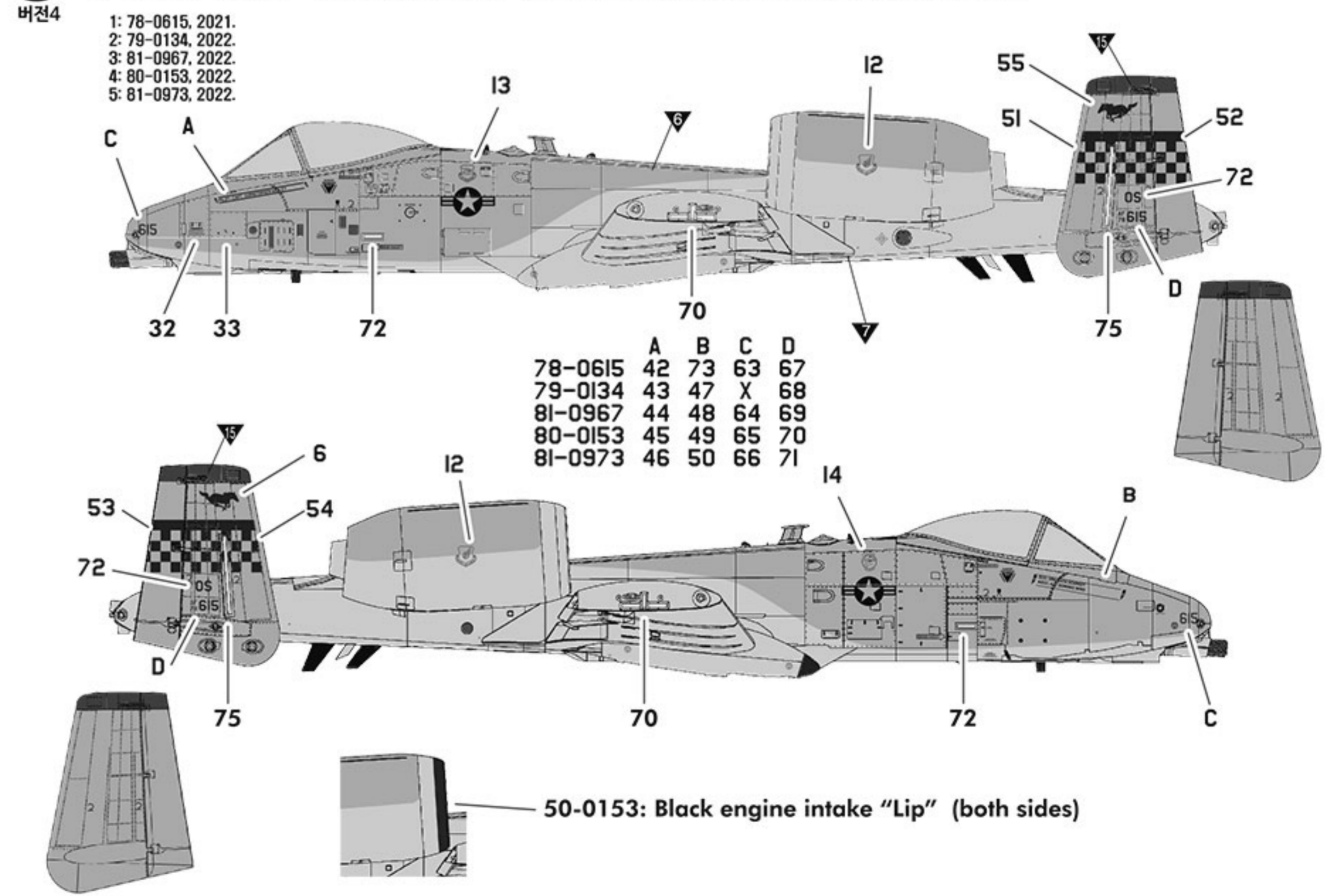

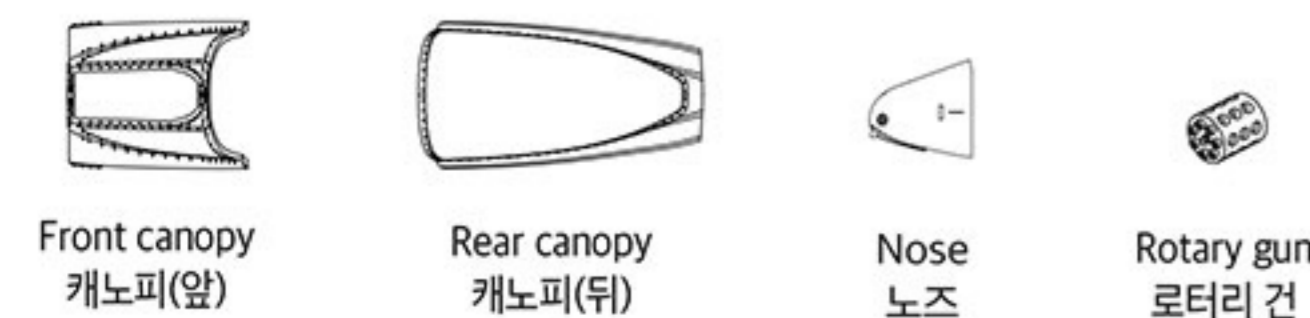
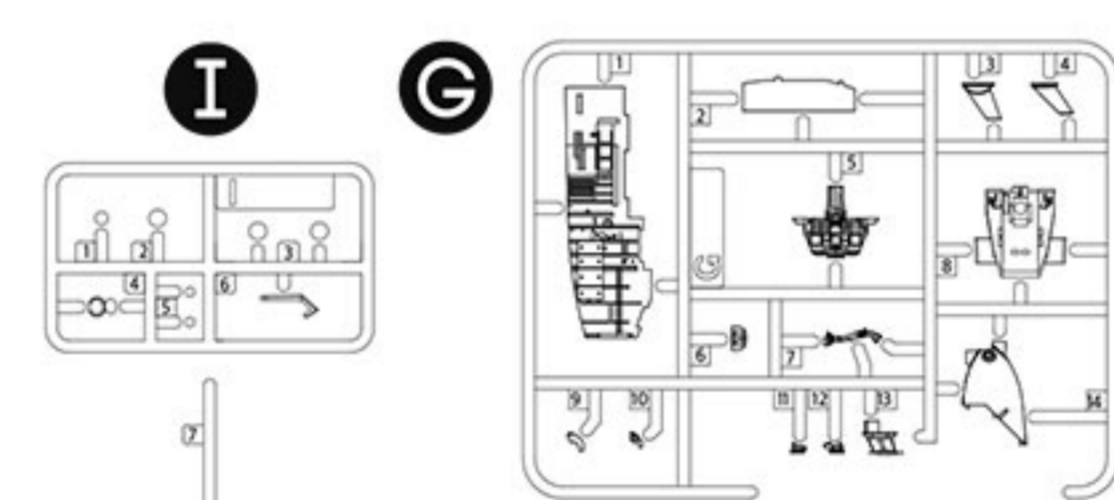
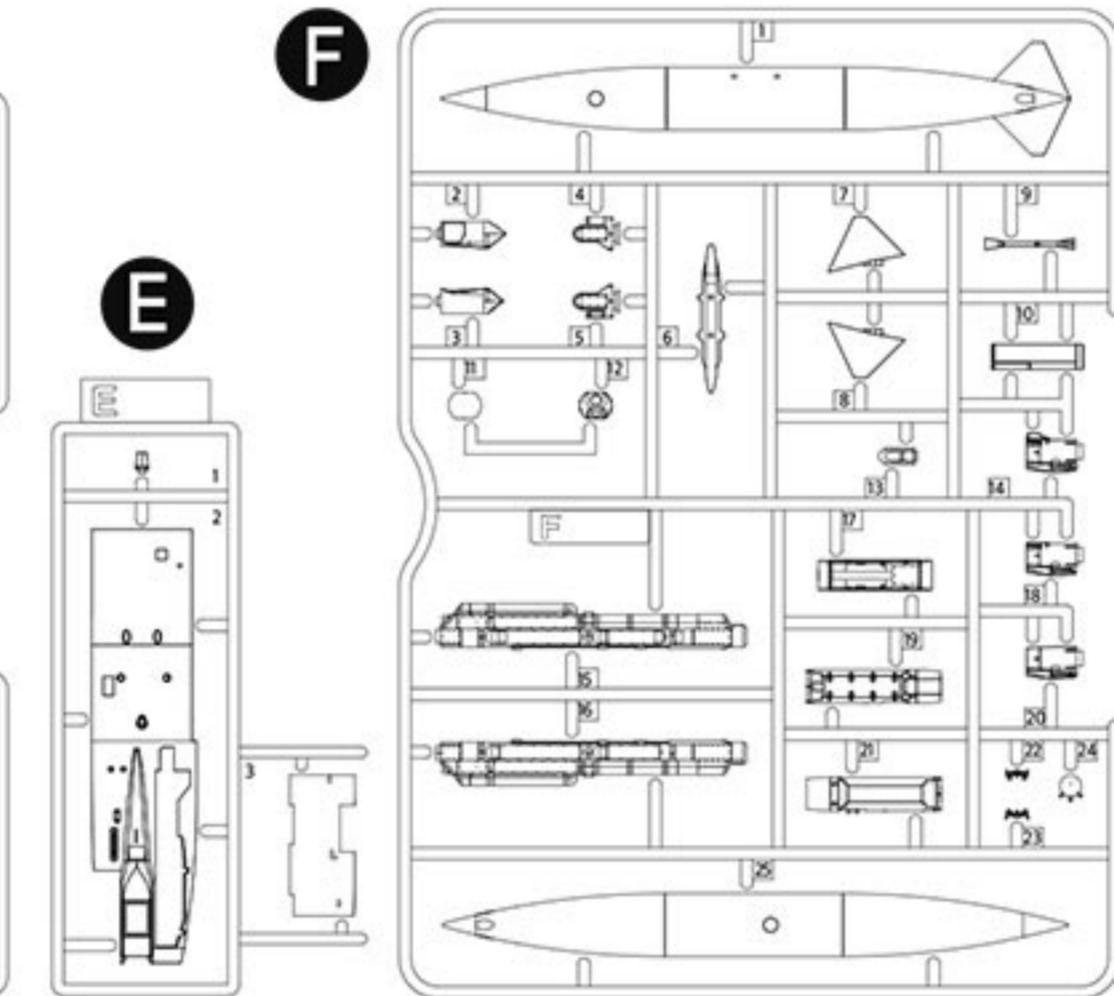
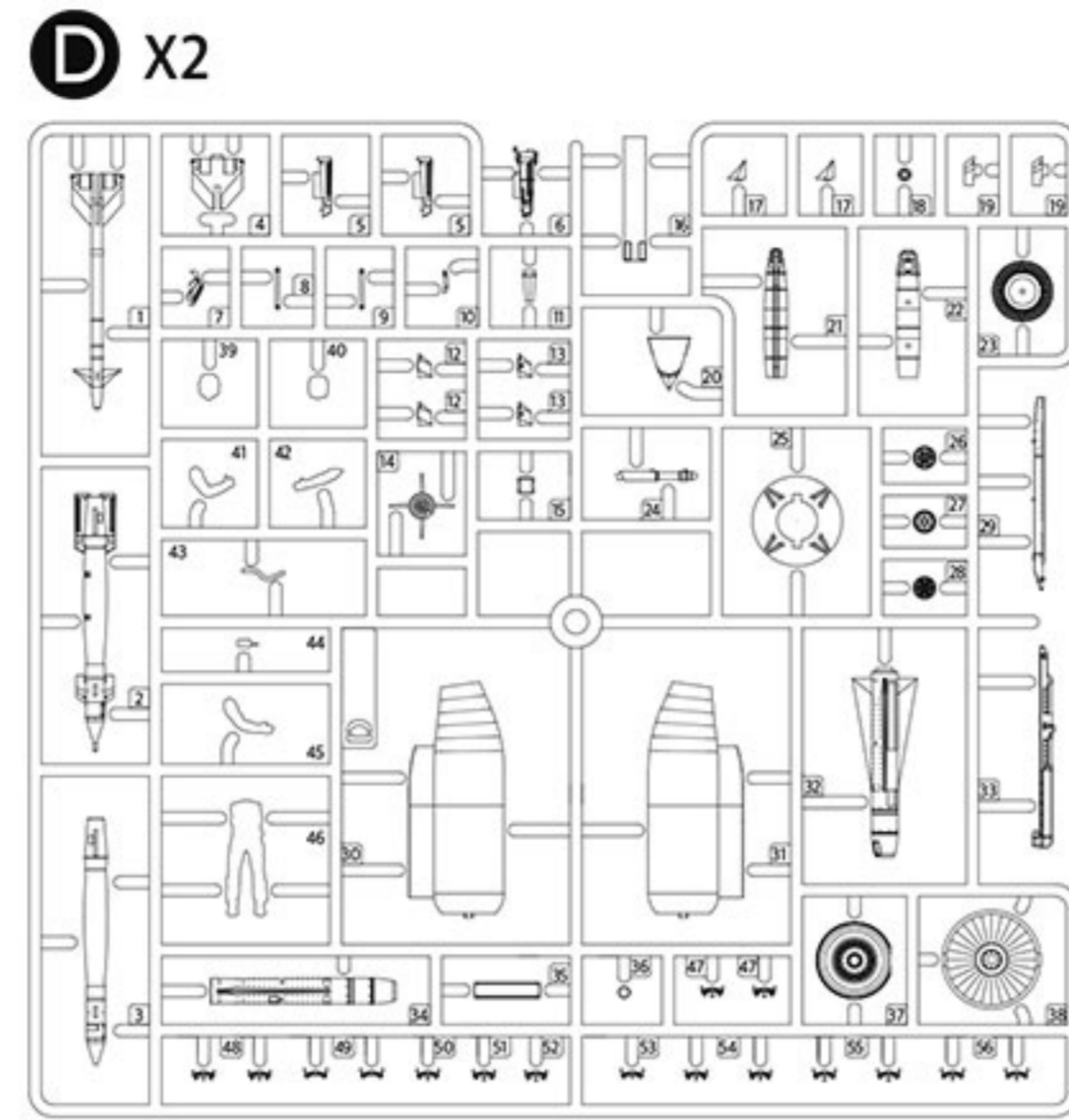
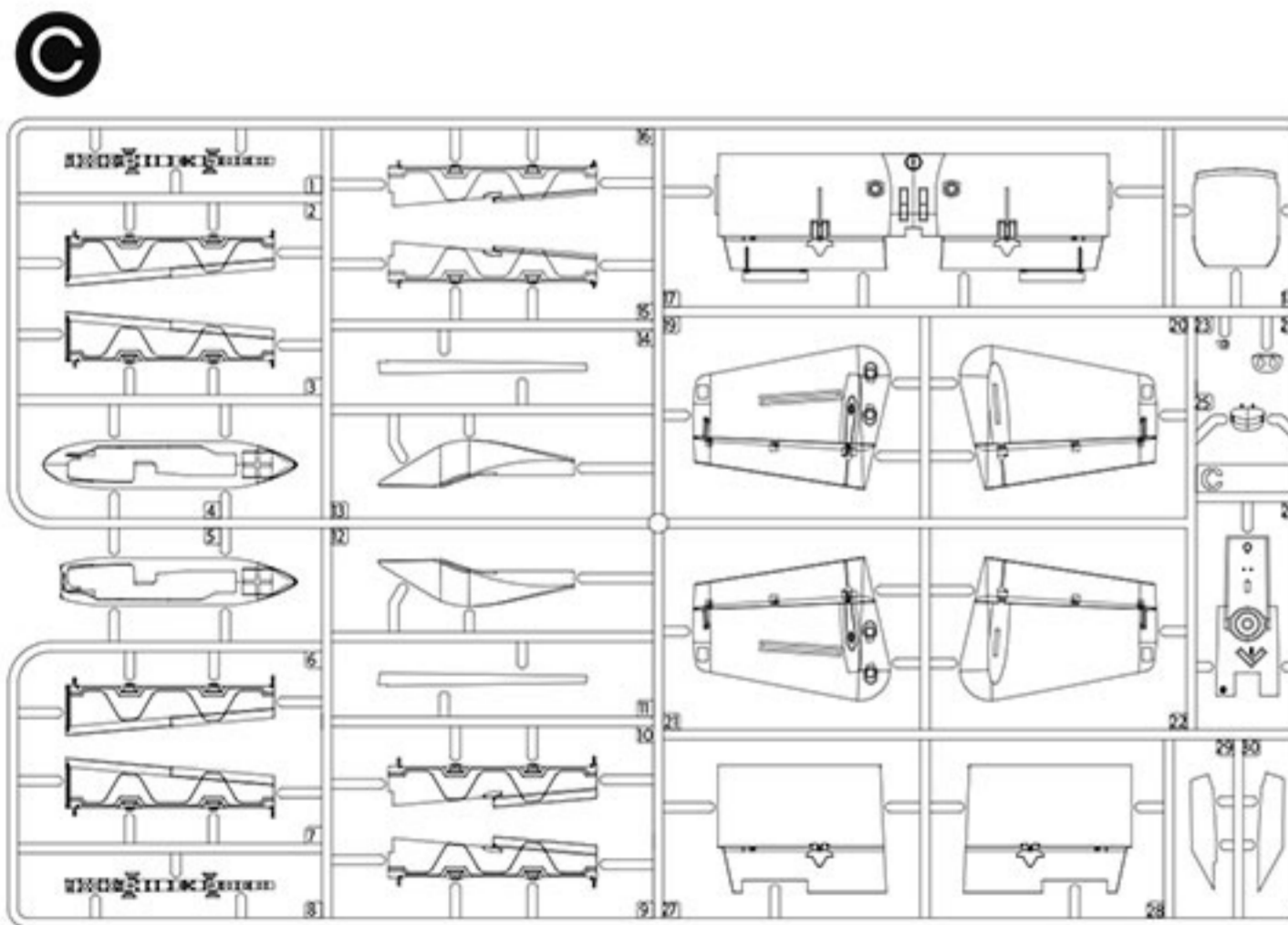
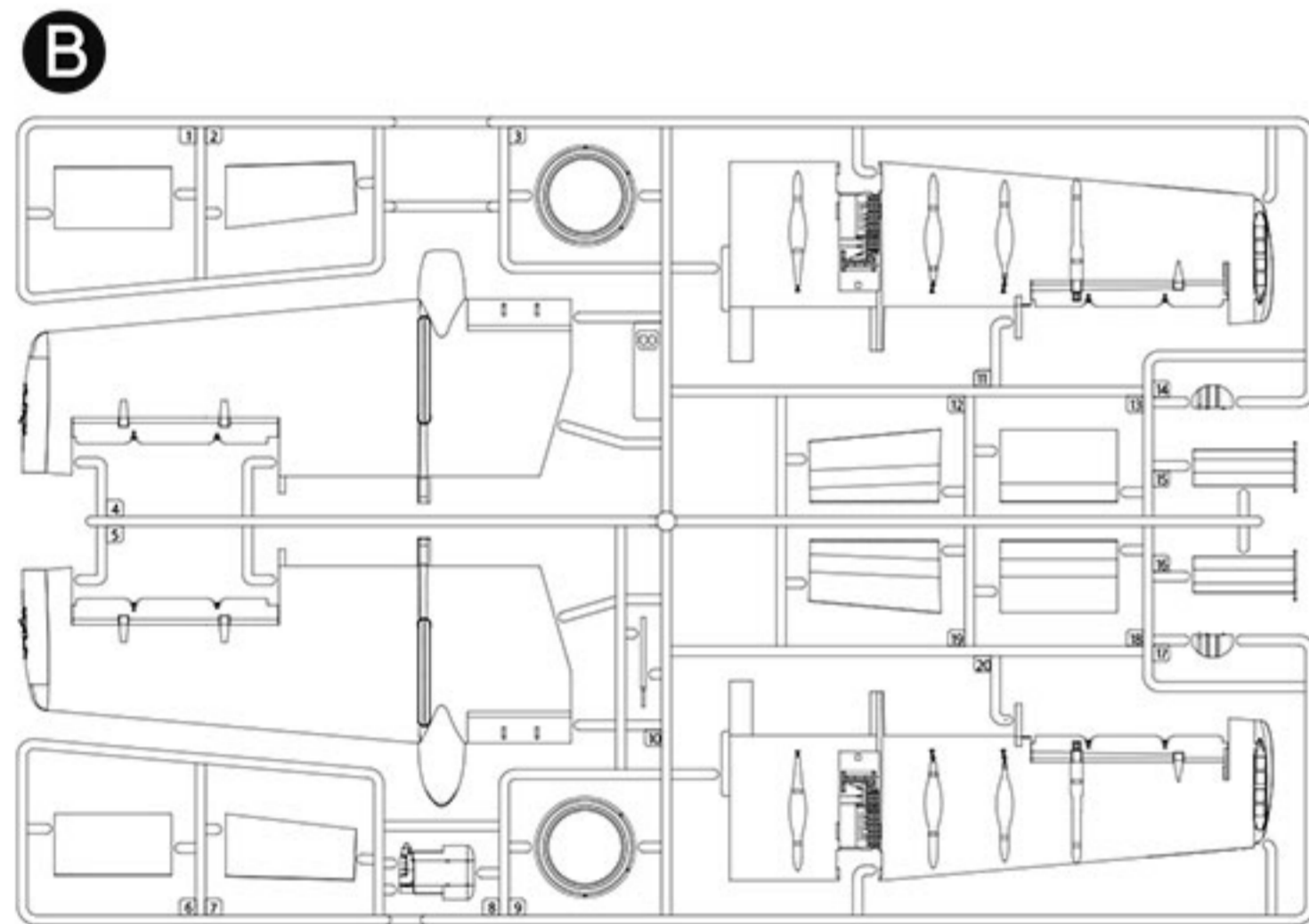
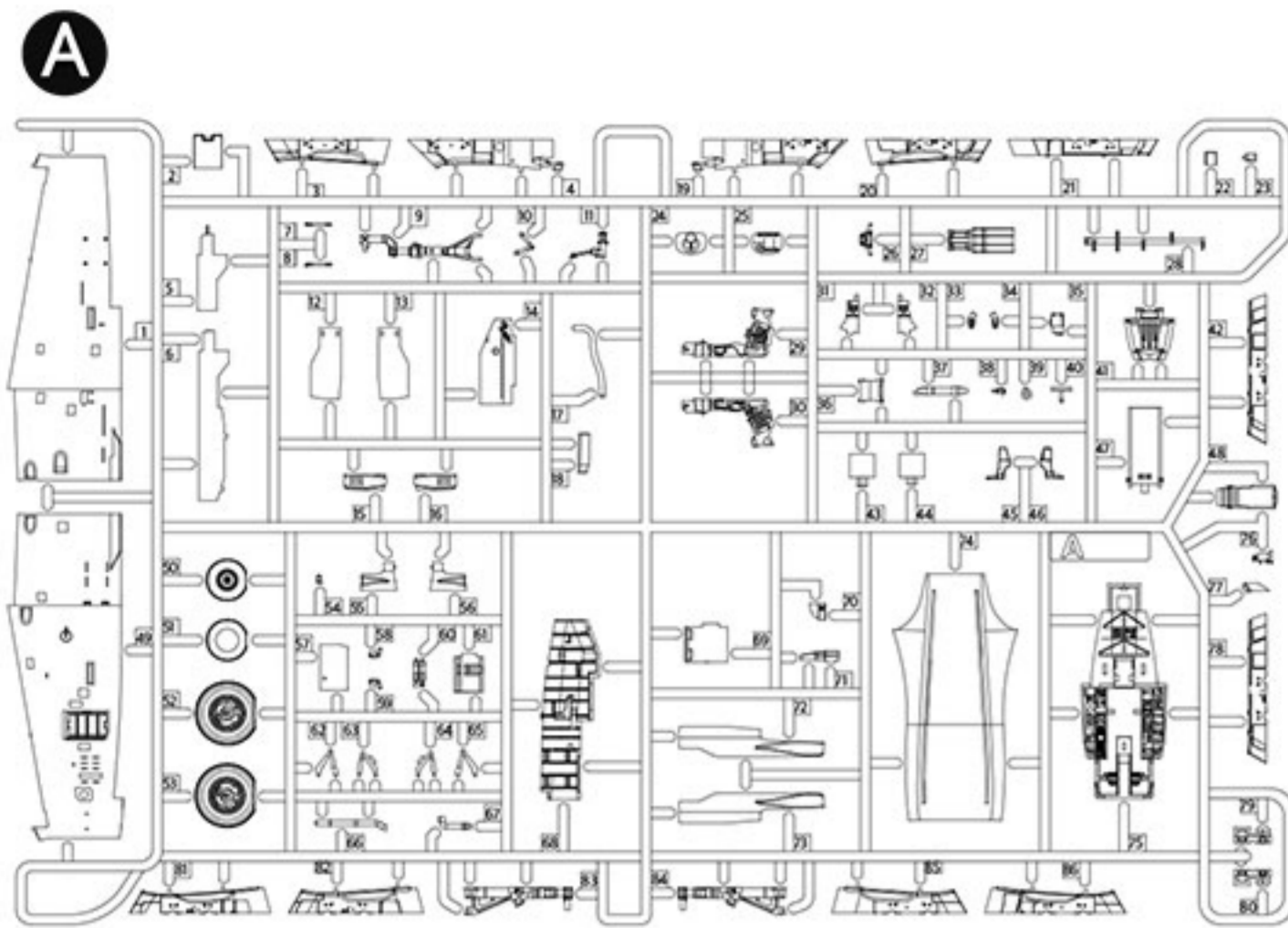

Front canopy 캐노피(앞) Rear canopy 캐노피(뒤) Nose 노즈 Rotary gun 로터리 건

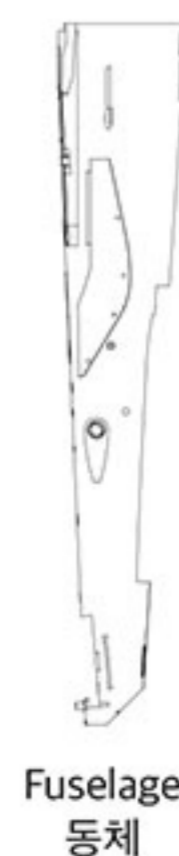

Fuselage 동체



Engine cover/ 엔진 커버

- Decal/ 전사지
- Masking tape/ 마스킹 테이프

Unused parts/ 불필요 부품
A6, A72, A73, F2, F3, F6, F10
F13, F14, F20, F21, I1



MANUAL 2

13 CEMENT
접착제 사용

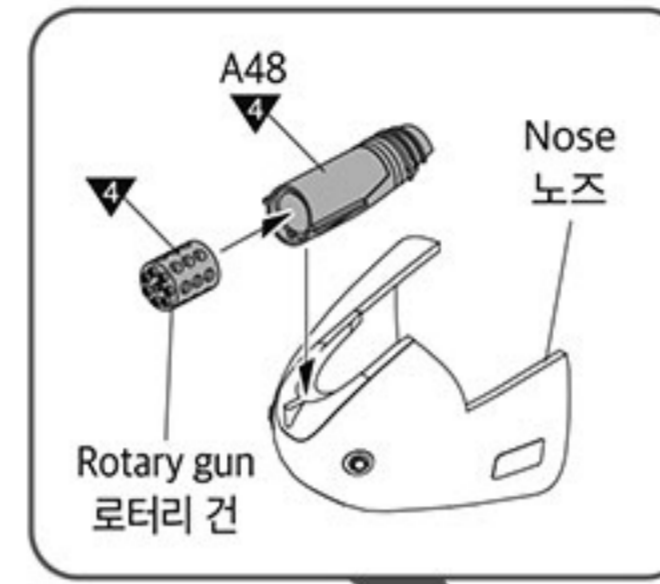

12

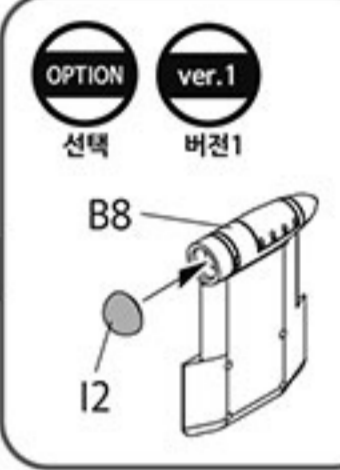
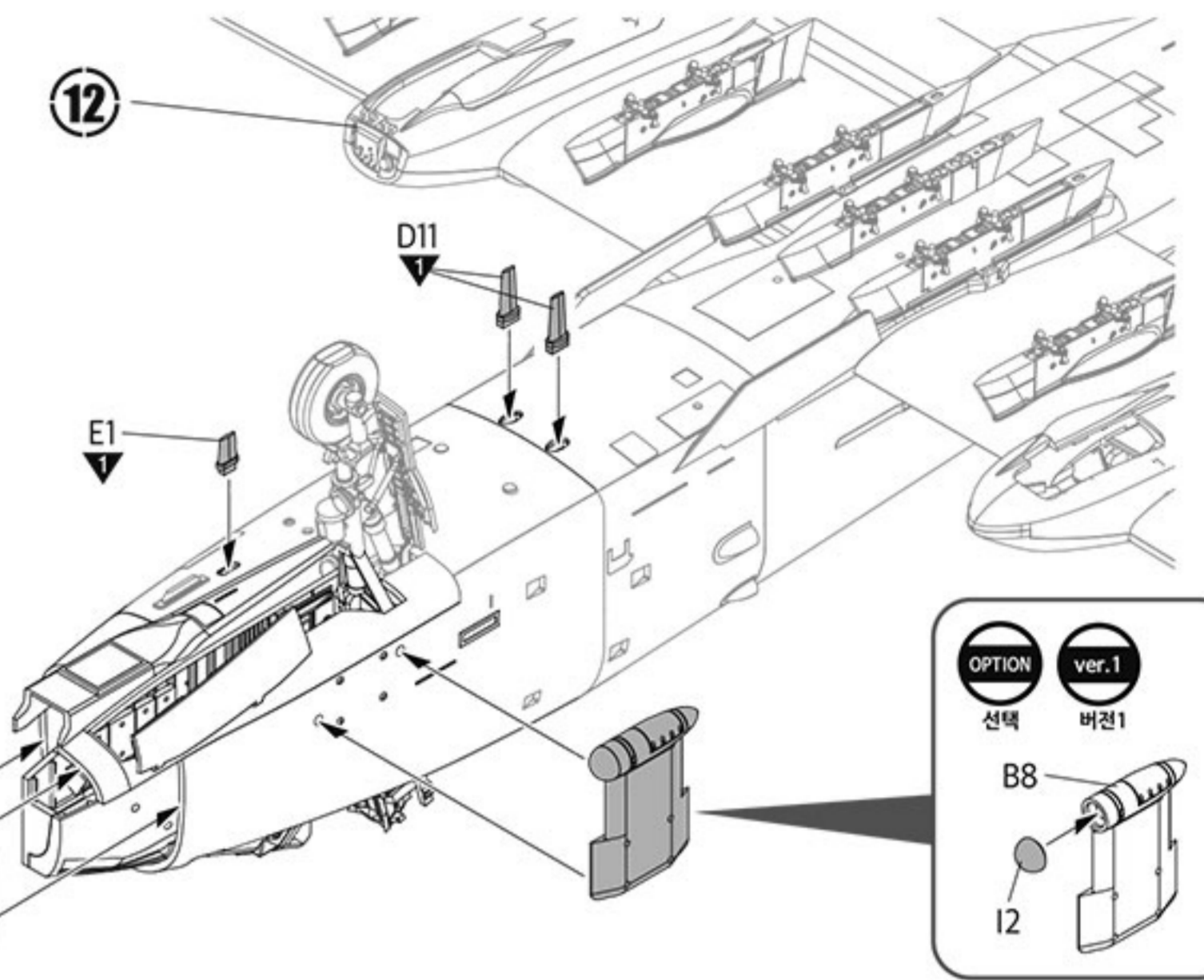

14 CEMENT
접착제 사용

